

# Operating Manual



## R&S<sup>®</sup> EVS 300 ILS / VOR Analyzer 3544.4005.02



R&S® is a registered trademark of Rohde & Schwarz GmbH & Co. KG.  
Proper names are trademarks of the respective owners.

Printed in the Federal  
Republic of Germany

**Rohde & Schwarz GmbH & Co. KG**  
Mühl Dorfstraße 15  
D-81671 München  
[www.rohde-schwarz.com](http://www.rohde-schwarz.com)



Certificate No.: **0502**

This is to certify that:

| Equipment Type | Identification No.: | Designation               |
|----------------|---------------------|---------------------------|
| <b>EVS 300</b> | <b>3544.4005.02</b> | <b>ILS / VOR Analyzer</b> |

complies with the provisions of the Directive of the Council of the European Union on the approximation of the laws of the Member States

- relating to electrical equipment for use within certain voltage limits (73/23/EEC revised by 93/68/EEC)
- relating to electromagnetic compatibility (89/336/EEC revised by 91/263/EEC, 92/31/EEC, 93/68/EEC)

Conformity is proven by compliance with the following standards:

- EN61010-1:2001
- EN55022:1998 + A1:2000 + A2:2003
- ETSI EN301489-1: V1.4.1
- ETSI EN301489-22: V1.3.1

Affixing th EC Conformity Mark as from: 2005

Cologne, 24.10.2005

**ROHDE & SCHWARZ GmbH & Co. KG**  
**Service Centre Cologne**  
**Graf-Zeppelin-Str. 18, D-51147 Cologne**  
Quality Assurance 5C-Q / Bremmekamp



# Content

|          |   |            |
|----------|---|------------|
| <b>1</b> | <b>General Information .....</b>  | <b>1-1</b> |
| 1.1      | Symbols and Cautions .....  | 1-1        |
| 1.2      | Unpacking the R&S® EVS 300 ILS / VOR Analyzer .....                             | 1-2        |
| 1.3      | Applications and Features of the<br>R&S® EVS 300 ILS / VOR Analyzer .....       | 1-3        |
| 1.3.1    | Applications of the R&S® EVS 300 ILS / VOR Analyzer .....                       | 1-3        |
| 1.3.2    | Features of the R&S® EVS 300 ILS / VOR Analyzer .....                           | 1-4        |
| 1.4      | Views of the Device .....   | 1-5        |
| 1.4.1    | Front View .....  | 1-5        |
| 1.4.2    | Rear View .....   | 1-5        |
| <b>2</b> | <b>Preparation.....</b>   | <b>2-1</b> |
| 2.1      | Setting up the Equipment .....  | 2-1        |
| 2.1.1    | Power Supply connection .....   | 2-1        |
| 2.1.1.1  | General.....  | 2-1        |
| 2.1.1.2  | Table Power Pack connection .....   | 2-2        |
| 2.1.1.3  | Connection to an external DC Power Source .....                                 | 2-2        |
| 2.1.2    | Connection of the Signal / Control-In / Outputs on the front of the device..... | 2-3        |
| 2.1.2.1  | Receiving antenna connection (26, 32) .....                                     | 2-3        |
| 2.1.2.2  | Power Supply connection (27) for an Active Receiving Antenna .....              | 2-4        |
| 2.1.2.3  | Headphone connection (28).....  | 2-4        |
| 2.1.2.4  | USB Port connection (Twin Port, 29).....  | 2-4        |
| 2.1.3    | Connection of the Signal/Control-In/Outputs on the back of the device .....     | 2-4        |
| 2.1.3.1  | External Power Supply output (AUX POWER, 3) .....                               | 2-4        |
| 2.1.3.2  | ANALOG 1 (5) and ANALOG 2 (4) signal outputs .....                              | 2-5        |
| 2.1.3.3  | Baseband input / Trigger input (6) .....  | 2-5        |
| 2.1.3.4  | GPS Control Port (7) .....  | 2-5        |
| 2.1.3.5  | Remote operation port (8).....  | 2-5        |
| 2.1.3.6  | LAN connection (9) .....  | 2-6        |
| 2.1.3.7  | Power Supply connection (10).....   | 2-6        |
| <b>3</b> | <b>Operation.....</b>   | <b>3-1</b> |
| 3.1      | Switch ON / OFF the R&S® EVS 300 ILS / VOR Analyzer.....                        | 3-1        |
| 3.1.1    | Starting process .....  | 3-1        |
| 3.1.2    | Battery powered operation .....   | 3-2        |
| 3.1.2.1  | Battery level indication .....  | 3-2        |
| 3.1.2.2  | Charging the Battery .....  | 3-3        |
| 3.1.2.3  | 12 / 24-DC / DC-Converter .....   | 3-3        |
| 3.1.2.4  | Charge level indication.....  | 3-4        |
| 3.1.3    | Internal clock .....  | 3-4        |
| 3.2      | Signal Parameters and Displays .....  | 3-5        |
| 3.2.1    | General.....  | 3-5        |
| 3.2.1.1  | Status Display (3**).....   | 3-5        |



|            |  |             |
|------------|--|-------------|
| <b>3.3</b> | <b>General Information about the Controls</b>                  | <b>3-6</b>  |
| 3.3.1      | Tens keyboard  | 3-6         |
| 3.3.2      | Rollkey  | 3-7         |
| 3.3.3      | Arrow buttons  | 3-8         |
| <b>3.4</b> | <b>Settings in the Setup menu</b>                              | <b>3-9</b>  |
| 3.4.1      | General  | 3-10        |
| 3.4.2      | General operating steps in the setup menu                      | 3-11        |
| 3.4.3      | RF Parameter setting   | 3-12        |
| 3.4.3.1    | Setting the Antenna Correction Factor on Channel 1 / Channel 2 | 3-13        |
| 3.4.3.2    | Analyse selection on Channel 1 / Channel 2                     | 3-13        |
| 3.4.3.3    | Setting the Base band signal level                             | 3-14        |
| 3.4.4      | Settings for Analogue Output 1 / 2                             | 3-14        |
| 3.4.4.1    | Setting the Analogue Out 1 / 2                                 | 3-15        |
| 3.4.4.2    | Setting the Baseband signal output CH 1 / CH 2                 | 3-15        |
| 3.4.4.3    | Setting the DDM range LLZ CH 1 / CH 2                          | 3-16        |
| 3.4.4.4    | Setting the DDM range GS CH 1 / CH 2                           | 3-16        |
| 3.4.5      | Setting the Display of the Measured data                       | 3-17        |
| 3.4.5.1    | Setting the DDM Measuring Units                                | 3-18        |
| 3.4.5.2    | Setting the SDM Measuring Units                                | 3-18        |
| 3.4.5.3    | Setting the Level Measuring Units                              | 3-18        |
| 3.4.5.4    | Setting the values range of the ILS phase                      | 3-19        |
| 3.4.5.5    | Setting the DDM polarity                                       | 3-19        |
| 3.4.5.6    | Setting the ILS bargraph display                               | 3-20        |
| 3.4.6      | F Step setting   | 3-20        |
| 3.4.7      | Setting the Data Logger  | 3-21        |
| 3.4.8      | Setting the Audio- und Display characteristics                 | 3-22        |
| 3.4.8.1    | Setting the AF Volume  | 3-23        |
| 3.4.8.2    | Setting the Display brightness                                 | 3-23        |
| 3.4.8.3    | Setting the Display Update Rate                                | 3-23        |
| 3.4.8.4    | Setting the Keyboard Beep (ON / OFF)                           | 3-24        |
| 3.4.8.5    | Setting the Loudspeaker (ON / OFF)                             | 3-24        |
| 3.4.8.6    | Setting the Low temp Display Saver (ON / OFF)                  | 3-24        |
| 3.4.9      | Setting the Communication interface                            | 3-25        |
| 3.4.9.1    | Setting of the Dynamic Host Configuration Protocol (DHCP)      | 3-26        |
| 3.4.9.2    | IP Address setting   | 3-26        |
| 3.4.9.3    | Netmask ID setting   | 3-26        |
| 3.4.9.4    | Gateway ID setting   | 3-27        |
| 3.4.9.5    | Setting the Baud rate of the Remote interface                  | 3-27        |
| 3.4.9.6    | Setting the Data bit of the Remote interface                   | 3-27        |
| 3.4.9.7    | Setting the Stop bit of the Remote interface                   | 3-28        |
| 3.4.9.8    | Setting the Parity property of the Remote interface            | 3-28        |
| 3.4.10     | Setting the General features                                   | 3-29        |
| 3.4.10.1   | Date setting   | 3-29        |
| 3.4.10.2   | Time setting   | 3-30        |
| 3.4.10.3   | Energy Saver setting (ON / OFF)                                | 3-30        |
| 3.4.10.4   | Setting the timer for the Energy Saver function                | 3-30        |
| 3.4.10.5   | Switch ON / OFF the Web interface                              | 3-31        |
| 3.4.10.6   | Switch ON / OFF the function "Boot on Power Up"                | 3-31        |
| 3.4.11     | Call-up the Error Logbook                                      | 3-32        |
| 3.4.12     | Call-up the Hardware / Software inventory list                 | 3-32        |
| 3.4.12.1   | Software Update  | 3-33        |
| 3.4.13     | Call-up the Device operating parameters                        | 3-33        |
| 3.4.14     | Software options   | 3-34        |
| 3.4.15     | Memory & Screenshots   | 3-35        |
| <b>3.5</b> | <b>Setting of the RF-Signal Adjustment</b>                     | <b>3-36</b> |

|             |   |             |
|-------------|---|-------------|
| <b>3.6</b>  | <b>Setting of the Squelch Threshold.....</b>                          | <b>3-37</b> |
| <b>3.7</b>  | <b>Setting the Measurement Interval Time.....</b>                     | <b>3-38</b> |
| <b>3.8</b>  | <b>AF-Volume setting.....</b>   | <b>3-39</b> |
| <b>3.9</b>  | <b>ILS mode operation.....</b>  | <b>3-40</b> |
| 3.9.1       | Signal Parameters and Display in the ILS mode.....                    | 3-40        |
| 3.9.1.1     | RF Parameter Section (1).....   | 3-40        |
| 3.9.1.2     | Measured Values Section (4).....                                      | 3-41        |
| 3.9.1.3     | Softkeys (2).....   | 3-43        |
| 3.9.2       | Setting the Receiving frequency in the ILS mode.....                  | 3-44        |
| 3.9.3       | Setting the Receiving channel in the ILS mode.....                    | 3-45        |
| 3.9.3.1     | ILS-Channel Frequency list.....                                       | 3-46        |
| 3.9.4       | Selection the Localizer / Glideslope mode.....                        | 3-47        |
| 3.9.5       | Switch over the Display view in the ILS mode.....                     | 3-47        |
| 3.9.6       | Processing Distortion measurements in ILS mode.....                   | 3-48        |
| 3.9.6.1     | Measured Values Section (4) of the ILS Distortion view.....           | 3-49        |
| 3.9.7       | ILS measurement modes.....  | 3-49        |
| 3.9.7.1     | Single signal measuring.....  | 3-50        |
| 3.9.7.1.1   | Select the Single signal measuring mode.....                          | 3-50        |
| 3.9.7.2     | Course and Clearance Signal measuring.....                            | 3-51        |
| 3.9.7.2.1   | Select the Course and Clearance signal measuring.....                 | 3-51        |
| 3.9.7.3     | Separate measurements of Course or Clearance signals.....             | 3-52        |
| 3.9.7.3.1   | Select the “CRS” or “CLR” measuring mode.....                         | 3-52        |
| 3.9.7.4     | Parallel Course and Clearance signal measuring (Option EVS-K3).....   | 3-53        |
| 3.9.7.4.1   | Select the CRS CLR measuring mode.....                                | 3-53        |
| 3.9.7.4.2   | Signal Parameters and Display in the CRS CLR window (Option).....     | 3-54        |
| <b>3.10</b> | <b>VOR mode operation.....</b>  | <b>3-57</b> |
| 3.10.1      | Signal Parameters and Display in the VOR mode.....                    | 3-57        |
| 3.10.1.1    | RF Parameter Section (1).....   | 3-58        |
| 3.10.1.2    | Measured Values Section (4).....                                      | 3-58        |
| 3.10.1.3    | Softkey (2).....  | 3-59        |
| 3.10.2      | Setting the Receiving frequency in the VOR mode.....                  | 3-60        |
| 3.10.3      | Setting the Receiving channel in the VOR mode.....                    | 3-61        |
| 3.10.3.1    | VOR-Channel Frequency List.....                                       | 3-62        |
| 3.10.4      | Switch over the Display view in the VOR mode.....                     | 3-63        |
| <b>3.11</b> | <b>MARKER BEACON mode operation.....</b>                              | <b>3-63</b> |
| 3.11.1      | Signal Parameters and Display in the MARKER BEACON mode.....          | 3-64        |
| 3.11.1.1    | RF Parameter Section (1).....   | 3-64        |
| 3.11.1.2    | Measured Values Section (4).....                                      | 3-65        |
| 3.11.1.3    | Softkeys (3).....   | 3-65        |
| 3.11.2      | Setting the Receiving frequency in the MARKER BEACON mode.....        | 3-66        |
| <b>3.12</b> | <b>F SCAN and FFT mode (Options) operation.....</b>                   | <b>3-67</b> |
| 3.12.1      | Signal Parameters and Display in the F SCAN mode (Option EVS-K1)..... | 3-68        |
| 3.12.1.1    | Spectrum-Display F SCAN (1).....                                      | 3-68        |
| 3.12.1.2    | Softkeys (2).....   | 3-69        |
| 3.12.2      | Frequency setting at F SCAN mode.....                                 | 3-70        |
| 3.12.2.1    | Softkeys (2) of the Frequency setting.....                            | 3-71        |
| 3.12.3      | Flow of a Frequency setting in F SCAN mode.....                       | 3-71        |
| 3.12.4      | Setting the IF bandwidth.....   | 3-72        |
| 3.12.5      | Setting the Reference level.....                                      | 3-72        |
| 3.12.6      | Setting the RF mode.....  | 3-73        |



- 3.12.7 Setting the Resolution (level scale)..... 3-73
- 3.12.8 Setting Trace function ..... 3-74
- 3.12.9 Calling up the Marker function ..... 3-75
  - 3.12.9.1 Softkeys (2) of the Marker function ..... 3-75
  - 3.12.9.2 Explanation of the different Marker functions ..... 3-76
- 3.13 FFT mode (Option) operation ..... 3-78**
  - 3.13.1 Signal Parameters and Display in the FFT mode (Option EVS-K4) ..... 3-79
    - 3.13.1.1 Spectrum-Display FFT (1)..... 3-79
    - 3.13.1.2 Softkeys (2) ..... 3-80
  - 3.13.2 Setting the Receiving frequency ..... 3-81
  - 3.13.3 Setting the FFT stop frequency ..... 3-82
  - 3.13.4 Setting a Window function ..... 3-82
  - 3.13.5 Switching between Logarithmic or Linear display (Log / Lin)..... 3-83
  - 3.13.6 Setting the Reference position ..... 3-83
- 3.14 Data Logger operation ..... 3-84**
  - 3.14.1 Signal Parameters and Display in the menu window "Dataset lists" ..... 3-85
    - 3.14.1.1 Dataset list (1) ..... 3-85
    - 3.14.1.2 Softkeys (2) of the menu window "Dataset list" ..... 3-87
    - 3.14.1.3 Memory Status Information (4) ..... 3-87
  - 3.14.2 Signal Parameters and Display in the menu window "Parameter settings" ..... 3-88
    - 3.14.2.1 Softkeys (2) of the menu window " Parameter settings" ..... 3-88
  - 3.14.3 Signal Parameters and Display in the menu window "ILS-Graph" ..... 3-89
    - 3.14.3.1 Softkeys (3) of the menu window "ILS-Graph" ..... 3-90
    - 3.14.3.2 Signal Parameters and Display in the menu window "ILS-Graph-Marker" ..... 3-91
      - 3.14.3.2.1 Softkeys (2) of the menu window "ILS-Graph-Marker" ..... 3-91
    - 3.14.3.3 Signal Parameters and Display in the menu window "ILS-Graph-Trace" ..... 3-92
      - 3.14.3.3.1 Softkeys (2) of the menu window "ILS-Graph-Marker" ..... 3-92
  - 3.14.4 Using the Data Logger for the storage of data ..... 3-92
    - 3.14.4.1 Setting the Logging Interval Time ..... 3-93
    - 3.14.4.2 Activation the Automatic ON / OFF function at measuring interval ..... 3-93
    - 3.14.4.3 Settings to the external Trigger mechanism of the Data Logger ..... 3-94
    - 3.14.4.4 Setting the Logging Channel..... 3-95
    - 3.14.4.5 Setting the Logging Source..... 3-95
    - 3.14.4.6 Start / Stopp the Automatic storing of the measured value ..... 3-96
  - 3.14.5 Selection of Data set list..... 3-96
  - 3.14.6 Processing a Dataset list..... 3-97
  - 3.14.7 Copy the current list onto an USB-memory-stick ..... 3-97
  - 3.14.8 Creating an individual Dataset list..... 3-98
    - 3.14.8.1 Graphic display of ILS data..... 3-100
- 3.15 Preset mode operation ..... 3-104**
- 3.16 The Auto Calibration ..... 3-107**
  - 3.16.1 Displays in calibration menu ..... 3-107
    - 3.16.1.1 Softkeys..... 3-108
  - 3.16.2 Auto Calibration operating..... 3-108
- 3.17 GPS function (Option) ..... 3-111**
  - 3.17.1 GPS operating (Option)..... 3-111
  - 3.17.2 Displays in the GPS menu ..... 3-111
- 3.18 Release of Software Options ..... 3-113**
- 3.19 Operation within the R&S® EVS 300 Web interface ..... 3-114**



|             |  |              |
|-------------|--|--------------|
| 3.19.1      | Call-up the Web interface .....  | 3-115        |
| <b>3.20</b> | <b>Remote Control of the R&amp;S® EVS 300 ILS / VOR Analyzer .....</b> | <b>3-116</b> |
| 3.20.1      | Operation via RS-232 interface .....                                   | 3-116        |
| 3.20.2      | Operation via LAN interface .....                                      | 3-116        |
| 3.20.3      | Remote Control Commands .....  | 3-116        |
| 3.20.3.1    | Mode related Control Commands .....                                    | 3-116        |
| 3.20.3.2    | Remote Control Commands of the ILS mode .....                          | 3-120        |
| 3.20.3.3    | Remote Control Commands of the VOR mode .....                          | 3-123        |
| 3.20.3.4    | Remote Control Commands of the MARKER BEACON mode .....                | 3-124        |
| 3.20.3.5    | Remote Control Commands of the Data Logger mode .....                  | 3-125        |
| 3.20.3.6    | Remote Control Commands of the Setup mode .....                        | 3-125        |
| <b>4</b>    | <b>Service .....</b>   | <b>4-1</b>   |
| <b>4.1</b>  | <b>Guarantee .....</b>   | <b>4-1</b>   |
| <b>5</b>    | <b>Maintenance .....</b>   | <b>5-1</b>   |
| <b>5.1</b>  | <b>Calibration .....</b>   | <b>5-1</b>   |
| <b>5.2</b>  | <b>Cleaning .....</b>  | <b>5-1</b>   |
| <b>5.3</b>  | <b>Software Update .....</b>   | <b>5-1</b>   |
| <b>6</b>    | <b>Interfaces of the Unit .....</b>                                    | <b>6-1</b>   |
| <b>6.1</b>  | <b>Front side interfaces .....</b>                                     | <b>6-1</b>   |
| 6.1.1       | Antenna input 1 (26) .....   | 6-1          |
| 6.1.2       | Active Antenna control (27) .....                                      | 6-1          |
| 6.1.3       | Headset output (28) .....  | 6-1          |
| 6.1.4       | USB interface (29) .....   | 6-2          |
| 6.1.5       | Antenna input 2 (32) .....   | 6-2          |
| <b>6.2</b>  | <b>Rear side interfaces .....</b>                                      | <b>6-2</b>   |
| 6.2.1       | AUX-Power output (3) .....   | 6-2          |
| 6.2.2       | Analogous output 2 (4) .....   | 6-3          |
| 6.2.3       | Analogous output 1 (5) .....   | 6-3          |
| 6.2.4       | Baseband input / Trigger input (6) .....                               | 6-3          |
| 6.2.5       | GPS Control interface (7) .....  | 6-4          |
| 6.2.6       | RS-232 interface (8) .....   | 6-4          |
| 6.2.7       | LAN interface (9) .....  | 6-4          |
| 6.2.8       | DC Power Supply input (10) .....                                       | 6-4          |
| <b>7</b>    | <b>Technical Data .....</b>  | <b>7-1</b>   |



**Figures**

Fig. 1-1 Front View of the ILS / VOR Analyzer R&S® EVS 300 ..... 1-7

Fig. 1-2 Back View of the ILS / VOR Analyzer R&S® EVS 300 ..... 1-9

# 1 General Information

## 1.1 Symbols and Cautions

The symbols, which will be used in the description, are explained below.



Caution: requires special attention!



Pointing finger, this symbol indicates important details!



***The making of all connections necessary for operation must only be done by authorized persons; otherwise damage may be caused to the equipment!***

***During a thunderstorm, the device must not be operated using a hand held antenna.***

***When connecting the equipment to the 12-V/24-V on-board power supply of a vehicle, it must be ensured that the negative pole of the battery is connected to the ground of the vehicle (GROUND)!***

***If there is a failure of the battery pack within the guarantee period, it must be changed through a Rohde & Schwarz Service Center!***

***Lithium/NiMH batteries must not be exposed to high temperatures or fire. Keep batteries away from children. If the battery is replaced improperly, there is danger of explosion. Only replace the battery by R&S type.***

***Lithium/NiMH batteries are suitable for environmentally friendly disposal or specialized recycling. They may only be disposed of in designated containers. Do not short-circuit the battery, fire hazard!***



### 1.2 Unpacking the R&S® EVS 300 ILS / VOR Analyzer

1. Unpack the **R&S® EVS 300 ILS / VOR Analyzer**.



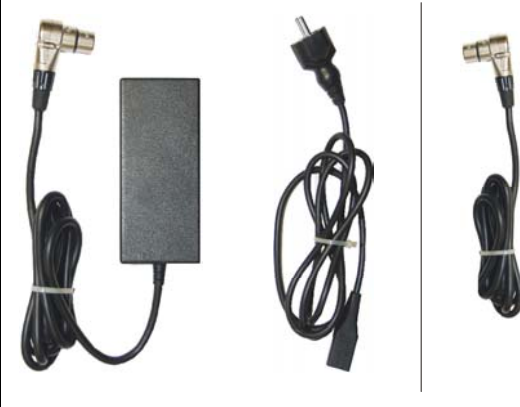

2. Examine the equipment for obvious damages.

3. Test the accessories supplied!
  - **Power pack with cable**
  - **XLR connection cable**
  - **Operating Manual**



*We recommend that you recycle the packaging material. If you have questions regarding service or other problems with the equipment, you can contact us by telephone or fax.*

|   |  |
|---|--|
| <br><b>ROHDE&amp;SCHWARZ</b><br>Service Center Cologne |  |
|    | (49) / 2203 / 49-51406<br>(49) / 2203 / 49-51402 |
|    | (49) / 2203 / 49-51642                           |

## 1.3 Applications and Features of the R&S® EVS 300 ILS / VOR Analyzer

### 1.3.1 Applications of the R&S® EVS 300 ILS / VOR Analyzer

The R&S® EVS 300 ILS / VOR Analyzer is used to test terrestrial radio navigation equipment in airports. The following components of Instrument Landing Systems (ILS) and VHF Omni directional Radio Range systems (VOR) can be tested:

- ILS (Instrument Landing System)
  - LLZ (Localizer) 108 ... 112 MHz
  - GS (Glideslope) 320 ... 340 MHz
  - Marker (Outer, Middle, Inner) 75 MHz
- Short and Medium distance navigation VOR (VHF Omni directional Radio Range)
  - CVOR (Conventional VOR) beacons 108 ... 118 MHz
  - DVOR (Doppler VOR) 108 ... 118 MHz

The following parameters are measured in the different modes of the equipment:

- ILS mode
  - DDM, SDM
  - RF level
  - ILS frequencies (course, clearance)
  - AM modulation degree for 90 / 150 Hz (with frequency display)
  - AM modulation degree (voice signal)
  - Distortion or 90 / 150 Hz
  - Identifier (modulation degree, frequency, code)
  - Phase (90 / 150 Hz signal)
- VOR mode
  - RF level
  - RF frequency
  - AM modulation degree for 30 / 9960 Hz (with frequency display)
  - AM distortion 9960 Hz
  - Identifier (modulation degree, frequency, code)
  - FM Index, FM Deviation
  - Bearing (30-Hz signals)
- MARKER BEACON (MB) mode
  - RF level
  - AM modulation degree for 400 / 1300 / 3000 Hz (with frequency display)
  - Identifier (modulation degree, frequency)
- F Scan mode (spectrum display, option)
  - Display of the frequency spectrum
- FFT mode (option)
  - FFT analysis (baseband signal)

Fields of application for the measurement technology are e.g.:

- Verification of terrestrial radio navigation systems (ILS and VOR systems)
- Dynamic Runway Measurement
- Function testing of CVOR / DVOR transmitter systems
- Course / Clearance (analysis of the parameters **without** switching off the transmitter systems through two independent measurement channels, option EVS-K3)
- Measurement and evaluation of all parameters at high interference field strengths



### 1.3.2 Features of the R&S® EVS 300 ILS / VOR Analyzer

The **R&S® EVS 300 ILS / VOR Analyzer** has the following features:

- Compact housing design and lightweight construction for mobile use, robust and splash proof (only if the bag is used)
- High-resolution 6.4" TFT display (VGA, 640 x 480); can also be easily read in direct sunlight
- Battery powered operation (option), intelligent battery management with quick charge, recharge and energy-saver modes, battery operating time 8 ... 10 hrs
- Display of battery level
- Remote control of the device through the RS-232 / LAN port
- Measurement data transfer over the ports (RS-232, LAN, USB)
- High long-term stability and reproducibility through digital signal processing from the IF position
- All measurement data of a mode (ILS, VOR, MARKER BEACON) is shown simultaneously in the display and may be stored in the internal data memory
- Display of the harmonic distortion (ILS-Distortion) in ILS mode
- Simultaneous and separate measurement of the course and clearance signals is possible in ILS mode through digital demodulation and filtering in the DSP
- Extendable by using a second signal processing channel
- Simultaneous measurement of the Localizer and Glideslope signals in ILS mode (with second channel, second channel, option)
- Measurement of the carrier frequency and the modulation frequencies with the accuracy of the reference oscillator
- Automatic assignment of the Glideslope to the corresponding Localizer frequencies, as under ICAO Annex 10
- High level measurement accuracy through built-in CAL Generator
- Remote control and data transfer through GSM modem (option)
- Data Logger:
  - all measured values of the modes ILS, VOR, MARKER BEACON may be simultaneously stored, even at the highest sampling rate,
  - Single and continuous recording of measured values,
  - Up to 999 lists (storage positions) can be compiled per mode,
  - Up to 1.000.000 measurements (measurement lines) can be recorded per list,
  - Graphic display of all data lists.
- Position data recording (GPS, DGPS option) through NMEA-0183 and custom-designed protocols
- Built-in speaker and headphone output
- Long-term measurements (max. 5 days autonomous operation)
- Long standby and measuring time with high-capacity data storage in autonomous operation
- Ports:
  - 2 x Y / T-writer (Range 1 ... 4) / AF signal output,
  - Baseband signal input, Trigger input
  - 2 x RS-232,
  - LAN,
  - 2 x USB 1.1

## **1.4 Views of the Device**

### **1.4.1 Front View**

Fig. 1-1 shows the front view of the R&S® EVS 300 ILS / VOR Analyzer

### **1.4.2 Rear View**

Fig. 1-2 shows the rack view of the R&S® EVS 300 ILS / VOR Analyzer





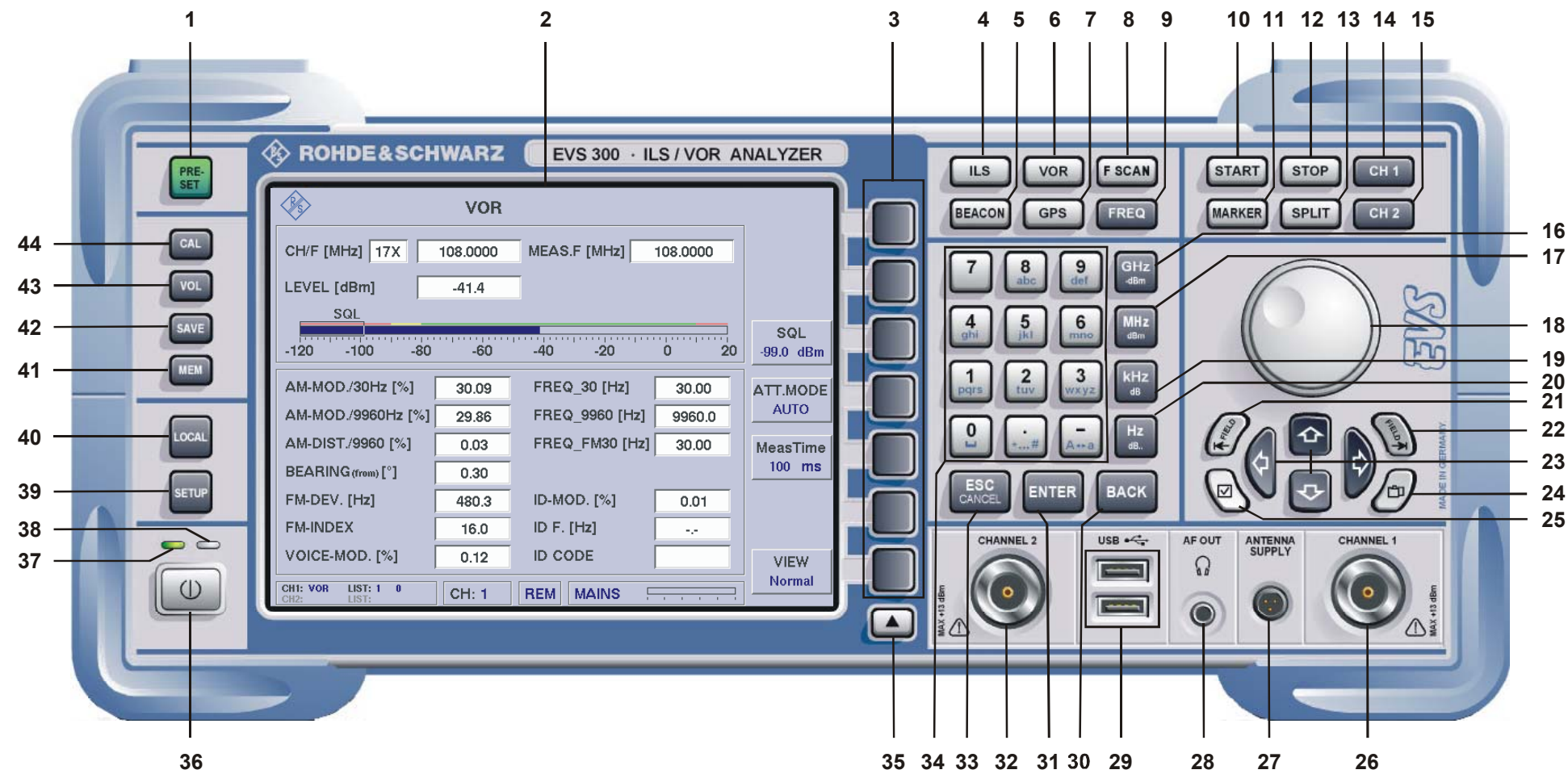

|    |  |    |   |    |   |
|----|--|----|---|----|---|
| 1  | PRESET key   | 16 | GHz key (Frequency input in GHz)                        | 31 | ENTER key (Confirmation key)  |
| 2  | TFT Colour Display ( 640 x 480 Pixels)                         | 17 | MHz key (Frequency input in MHz)                        | 32 | Channel 2 (Antenna input 2 (option), N plug)  |
| 3  | Softkeys (Program-dependent function keys)                     | 18 | Rollkey with ENTER function                             | 33 | ESC key (Cancel input)  |
| 4  | ILS mode key (selection of ILS mode)                           | 19 | kHz key (frequency input in kHz)                        | 34 | Numerical keypad (numerical input)  |
| 5  | MARKER BEACON mode key (selection of MARKER BEACON mode)       | 20 | Hz key (frequency input in Hz)                          | 35 | Softkey extension (active in several menu windows, indication in the display 1/2 resp. 2/2 ▲) |
| 6  | VOR mode key (selection of VOR mode)                           | 21 | Not set   | 36 | POWER key (ON / OFF switch)   |
| 7  | GPS key (selection of GPS function, option)                    | 22 | Not set   | 37 | Operating display (Power "ON")  |
| 8  | F SCAN mode key (selection of F Scan-/ FFT mode, option)       | 23 | Arrow (cursor) keys                                     | 38 | Charge control display  |
| 9  | FREQ Editor key (frequency- or channel input, toggle function) | 24 | Screenshot key (Stored image of a current display)      | 39 | SETUP key (selection of SETUP menu)   |
| 10 | START key (activates continuous saving of values)              | 25 | Not set   | 40 | LOCAL key (Switch between Local / Remote)   |
| 11 | Marker key (marker function)                                   | 26 | Channel 1 (Antenna input 1, N plug)                     | 41 | MEM key (selection of Data Logger)  |
| 12 | STOP key (stops continuous saving of values)                   | 27 | ANTENNA SUPPLY (DC output for active receiving antenna) | 42 | SAVE key (Saves the current measurement data)   |
| 13 | SPLIT key (simultaneous display of both channels)              | 28 | AF OUT (headphone output)                               | 43 | VOL key (volume setting)  |
| 14 | CH1 key (selection of reception channel 1)                     | 29 | USB (USB 2x 1.1 ports)                                  | 44 | CAL key (Auto Calibration, with built-in CAL Generator)                                       |
| 15 | CH2 key (selection of reception channel 2, option)             | 30 | BACK key (backspace key)                                |    |   |

Fig. 1-1 Front view of the R&S® EVS 300 ILS / VOR Analyzer



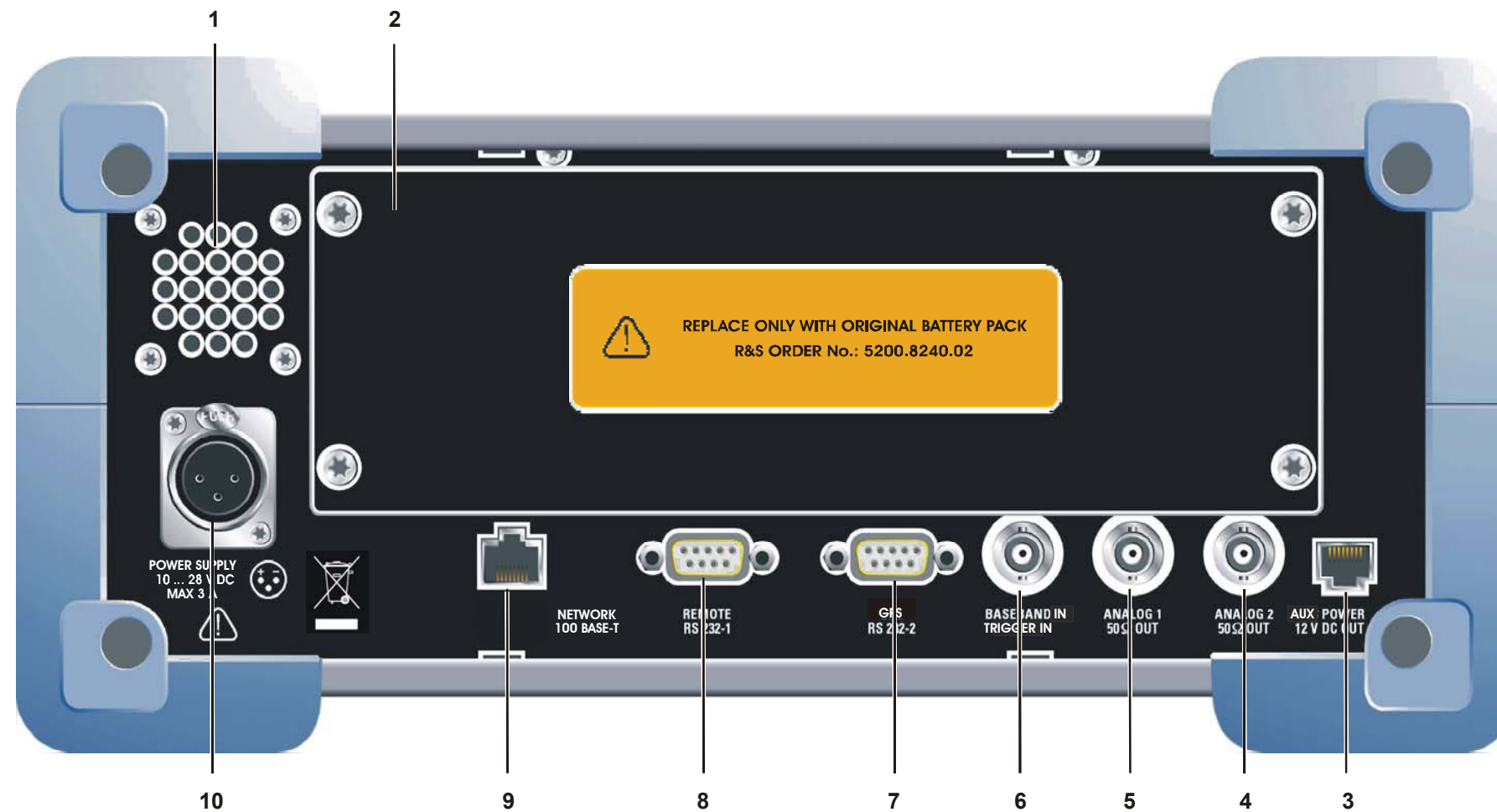

|    |   |
|----|---|
| 1  | Speaker   |
| 2  | Battery panel with battery pack (NIMH 13.2 V, 7.6 AH)   |
| 3  | AUX POWER (12VDC OUT) (DC output to power supply for an external device as e.g. a GSM modem)                                  |
| 4  | ANALOG 2 ( 50 Ω OUT) output for the analog baseband signal or, if in ILS mode, as analog DDM output (selection through setup) |
| 5  | ANALOG 1 ( 50 Ω OUT) output for the analog baseband signal or, if in ILS mode, as analog DDM output (selection through setup) |
| 6  | BASEBAND IN / TRIGGER IN  |
| 7  | GPS RS 232-2, port connection of a GPS receiver (not supplied)  |
| 8  | REMOTE RS 232-1 port  |
| 9  | NETWORK 100 BASE-T (LAN connection)   |
| 10 | POWER SUPPLY (10 ... 28 VDC) power supply connection for table power pack/external feed                                       |

Fig. 1-2 Back view of the R&S® EVS 300 ILS / VOR Analyzer



## 2 Preparation

### 2.1 Setting up the Equipment

The **R&S® EVS 300 ILS / VOR Analyzer** can be operated in a variety of places without detrimental effects on its features. Even the movement caused by transportation or mobile use will not impair its functioning.



***The device operates at ambient temperatures between -10 ... +55 °C.  
Storage temperature range -20 ... +70 °C.***

#### 2.1.1 Power Supply connection

##### 2.1.1.1 General

To ensure high mobility and flexibility in the use of the **R&S® EVS 300 ILS / VOR Analyzer**, the device must be operated only on DC power (10 ... 28 VDC). This can be supplied from the table power pack or from external DC power sources (with the corresponding technical data (10 ... 28 VDC, 3.0 A)).



***Start up, the device (with option "battery") should be operated using the supplied table power pack (charging time will vary with the condition of the battery pack, max. 4 hours), in order to charge the battery pack completely!***



***The power connection plug (table power pack) must only be plugged into a two-pin grounded socket!***

**2.1.1.2 Table Power Pack connection**



**When operating on the 230 V AC power supply only the supplied table power pack must be used!**

The R&S® EVS 300 ILS / VOR Analyzer is to be connected to the table power pack as follows:

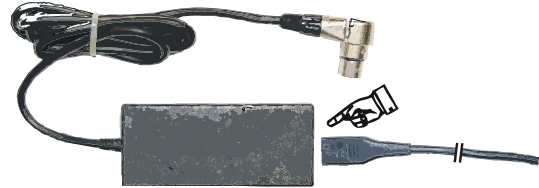
1. Connect the power cable to the table power pack and to a main power socket.

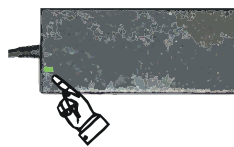

2. The green operating LED of the table power pack will light up.



3. Connect the DC connector of the table power pack to the POWER supply connection (10) on the back of the device.

**2.1.1.3 Connection to an external DC Power Source**

The device can be operated directly from an external DC power source (10 ... 28 V DC). However, it must be ensured that there is a DC supply through a line cross-section of at least 1.5 mm<sup>2</sup>, a cable protector (3 AT) and a 3-pin **XLR plug** to connect the device.



**An XLR connection cable is supplied with the R&S® EVS 300 ILS / VOR Analyzer.**

The R&S® EVS 300 ILS / VOR Analyzer is connected to an external DC power source as follows:

1. Connect the DC supply (XLR connection cable) to the POWER Supply connection (10) on the back of the device.



**When connecting the device to an external DC power source, there must be electrical protection through cable protection (3 AT) or on-board protection!**

## 2.1.2 Connection of the Signal / Control-In / Outputs on the front of the device

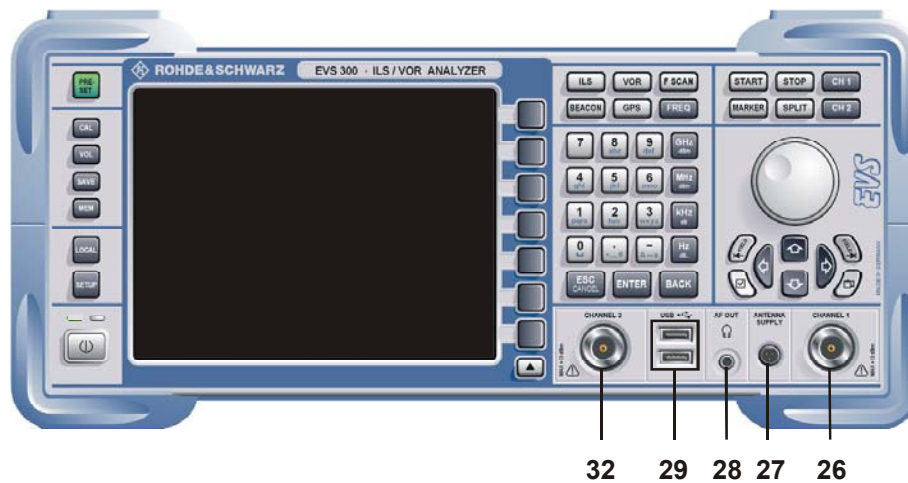

### 2.1.2.1 Receiving antenna connection (26, 32)

On the RF-inputs (Channel 1 (26) and Channel 2 (32, optional), the R&S® EVS 300 ILS / VOR Analyzer is connected with one of the receiving antennae (max. +13 dBm) corresponding to the frequency range. The RF inputs are designed as N plugs.



**Channel 2 is supplied as an option.**



**2.1.2.2 Power Supply connection (27) for an Active Receiving Antenna**

Through the ANTENNA SUPPLY connection (27), DC power (12 VDC, 300 mA) is fed to the power supply of an active receiving antenna.

**2.1.2.3 Headphone connection (28)**

Connection of a headphone with a 3.5 mm jack plug into AF OUT plug (28).

**2.1.2.4 USB Port connection (Twin Port, 29)**

USB 1.1 connections for storage devices e.g. Memory Stick.



*The company Rohde & Schwarz recommend USB memory sticks without "security feature". The USB memory sticks supplied by the Kingston company or SanDisk have demonstrated proven effectiveness.*

**2.1.3 Connection of the Signal/Control-In/Outputs on the back of the device**

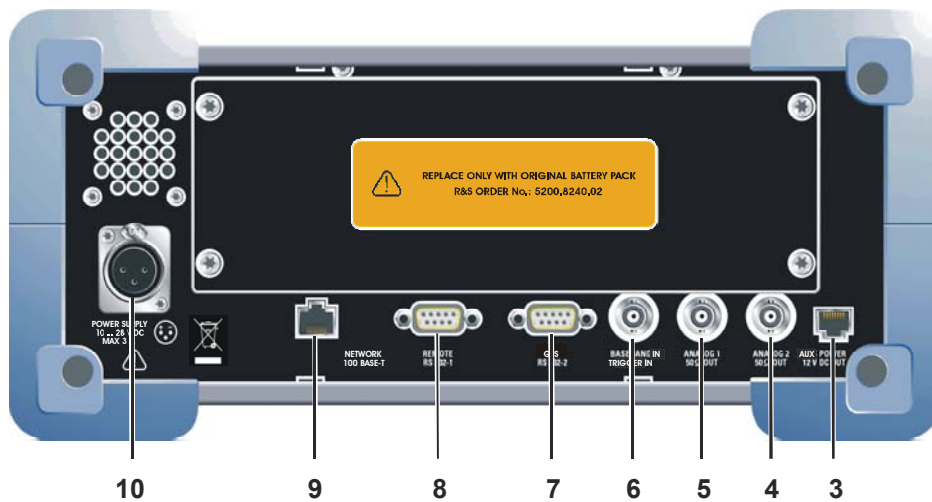

**2.1.3.1 External Power Supply output (AUX POWER, 3)**

Through the AUX POWER (3), DC output (12 VDC, 300 mA) to power supply for an external device as e.g. a GSM modem



### 2.1.3.2 ANALOG 1 (5) and ANALOG 2 (4) signal outputs

The analog signal outputs (BNC plug, 50 Ω) ANALOG 1 (5) and ANALOG 2 (4) may be used either as output for the analog baseband signal or, if in ILS mode, as analog DDM output. The respective assignment (BB OUT / DDM) will be set in the setup function. In addition, the option between FULL (demodulator bandwidth) or Audio (frequency range, 300 ... 3000 Hz) can also be selected for the baseband output in the setup. In addition, the scaling of the XY values can be set in the setup for the Localizer and Glideslope modes.

Scaling of the XY values (setting Range 1 ... 4 in the setup)

| Range   | Localizer                        | Glideslope                        |
|---------|----------------------------------|-----------------------------------|
| Range 1 | 0.0 ±0.25 DDM<br>≅ 0.5 V ±0.5V   | 0.0 ±0.5 DDM<br>≅ 0.5 V ±0.5V     |
|         | 0.0 ±0.025 DDM<br>≅ 0.5 V ±0.5V  | 0.0 ±0.05 DDM<br>≅ 0.5 V ±0.5V    |
|         | 0.0 ±0.0258 DDM<br>≅ 0.5 V ±0.5V | 0.0875 ±0.05 DDM<br>≅ 0.5 V ±0.5V |
|         | 0.0 ±0.5 DDM<br>≅ 0.5 V ±0.5V    | 0.175 ±0.05 DDM<br>≅ 0.5 V ±0.5V  |

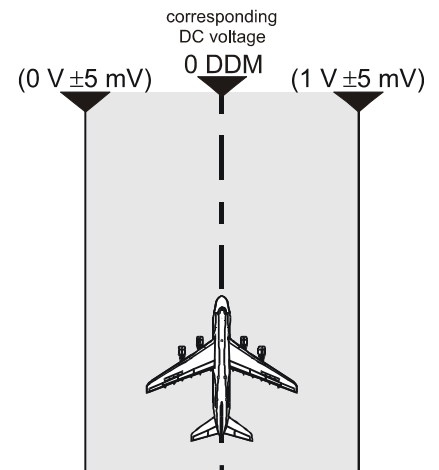

### 2.1.3.3 Baseband input / Trigger input (6)

Through BASEBAND IN (6) input (BNC plug, 1 MΩ), a baseband signal can be supplied to the **R&S® EVS 300 ILS / VOR Analyzer** for further analysis of typical AF parameters (e.g. level, frequency, modulation degree). In addition, this input may also be used as an external triggering mechanism of the Data Logger. The selection as well as the settings of the input will be done in the setup function.

### 2.1.3.4 GPS Control Port (7)

Through the GPS-RS 232-2 port (7) (9 pin Sub-D plug), a GPS receiver is. The NMEA protocol data is read in and displayed in GPS mode (Option EVS-K2).

### 2.1.3.5 Remote operation port (8)

Through the **RS 232 interface 1** (8) (9 pin Sub-D plug), all functions of the **R&S® EVS 300 ILS / VOR Analyzer** device can be operated remotely from a PC / terminal. Thus, the device can be operated through the commonly used terminal programs (e.g. HyperTerm™, ProCommPlus...). The port parameters are adjustable.

**2.1.3.6 LAN connection (9)**

Through the **LAN connection (Fast Ethernet) (9)**, all functions of the device and the data transfer of the measurement data of the **R&S® EVS 300 ILS / VOR Analyzer** can be remotely operated from a PC / network. IP Addresses and subnet mask identifier are set in the setup menu. The data transfer rate is 100 Mbit/s.

**2.1.3.7 Power Supply connection (10)**

Through the power supply connection (POWER SUPPLY (10), XLR plug.), the table power pack or an external DC power source (10 ... 28 VDC) is connected.



***When connecting the equipment to an external DC power source, electrical protection must be provided through cable protection (3 AT) or on-board protection!***

### 3 Operation

#### 3.1 Switch ON / OFF the R&S® EVS 300 ILS / VOR Analyzer

To switch on or off the unit press the "Power" (1) button.

When the unit is switched on the power-LED (2, green) lights.

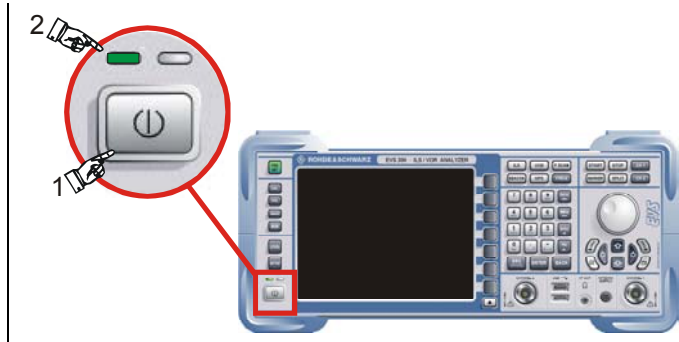



 **If the unit is driven by the belonging power supply or by an external DC-power supply >22 VDC, the installed accumulators will be charged as well when the unit is switched on as when it is switched off!**

##### 3.1.1 Starting process

The boot process of the **R&S® EVS 300 ILS / VOR Analyzer** takes about 50 s and will be indicated by a white progressing bar. Then the unit switches over automatically into the last using measurement mode.

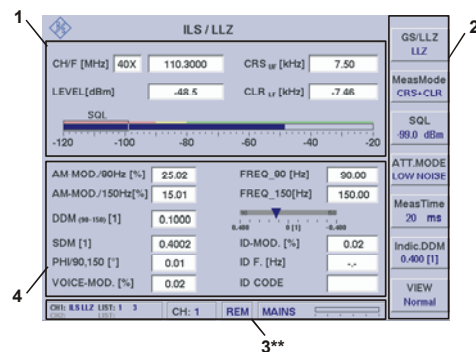
 **The unit always switches over into that measurement mode, which was activated when switching off the unit.**



 **If a failure occurs when booting the unit, switch it off and make a restart after a few seconds. If a failure occurs again we recommend to contact Rohde & Schwarz.**



3.1.2 Battery powered operation



The battery may be ordered as option EVS-B3!

When cutting the R&S® EVS 300 ILS / VOR Analyzer from an external power supply, it automatically switches over into battery operation.

The operating time is about 8 ... 10 h (medium display brightness) with a completely charged battery. For an anytime battery charge monitoring there is a battery capacity indication (BATTERY), the battery status ( bargraph) will be shown in the status field of the display.

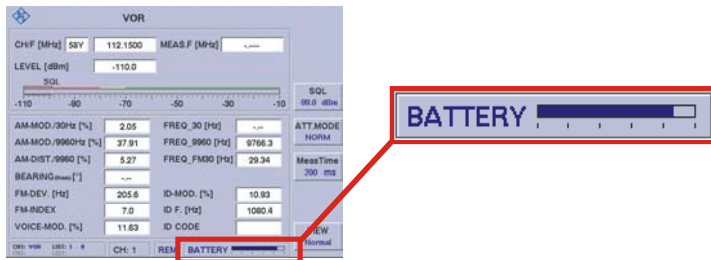

When running the R&S® EVS 300 ILS / VOR Analyzer with the Option EVS-B1 or with external equipment (e.g. active receiver antennas, GPS-receiver), the operating time will reduce accordingly.

3.1.2.1 Battery level indication

Battery level is indicated by the display "BATTERY".

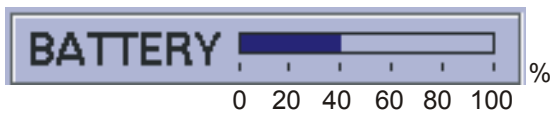

|                                      |   |
|--------------------------------------|---|
| Battery level 100%-power             | about 8 ... 10 hours operation time (with medium display brightness, 1* |
| Battery level about 80 ... 20%-power | about 1 ... 6 hours operation time (with medium display brightness, 1*  |
| Battery level about 20 ... 0%-power  | about 1 hour operation time (with medium display brightness, 1*         |

1\* without option EVS-B1 and external loads



If the battery becomes discharged, the word "EMPTY" will be displayed, accompanied by a loud beeping sound. Since the device will switch itself off after a few minutes when this stage is reached, the beep sound will be repeated every two minutes. A double beep sound indicates the device is switching itself off.



### 3.1.2.2 Charging the Battery

The **R&S® EVS 300 ILS / VOR Analyzer** has an intelligent battery management system with quick charging, recharging and conserve charging methods. The charging circuit is protected by an overload protection and an overheating protection.

 **The charge time is about 3.5 ... 4 hours (standby / operation)**

Generally the accumulators can be charged in operation with the power supply or with an external voltage supply more than 22 VDC.

 **The accumulators will not be charged with a voltage supply less than 22 VDC!**

In operation the battery level display changes to the indication "CHARGE".

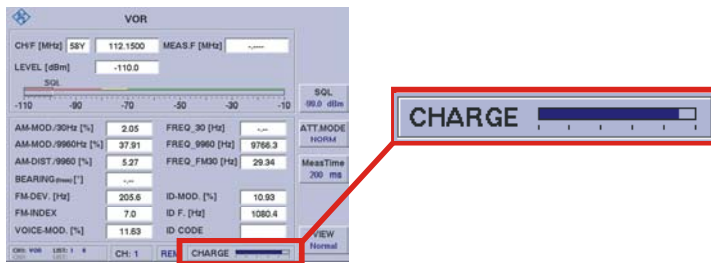

The (yellow) LED charge indicator displays the current charge level of the battery (while the device is turned on or off).

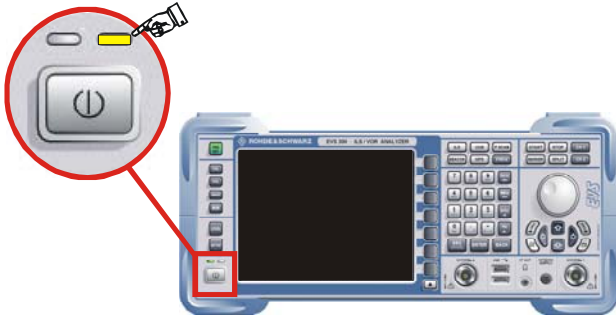

### 3.1.2.3 12 / 24-DC / DC-Converter

To facilitate a charging with supply voltages less than 22 VDC, the 12 / 24-DC-Converter is linked between.

 This converter is available as an accessories EVS-Z5, order number 5200.6619.02.



### 3.1.2.4 Charge level indication

Battery charging is indicated by the display "CHARGE".

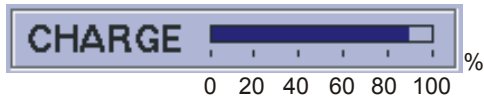

|                               |   |
|-------------------------------|---|
| Charge level about 0 ... 20%  | about 3 ... 4 hours remaining charge time |
| Charge level about 20 ... 80% | about 1 ... 3 hours remaining charge time |
| Charge level 80 ... 100%      | about 0 ... 1 hours remaining charge time |



*The battery level is reached of 100 per cent this is indicated by the display "Full".*



### 3.1.3 Internal clock

The R&S® EVS 300 ILS / VOR Analyzer contains an internal clock. A Lithium battery supplies this clock with the necessary voltage when the unit is switched off. If the Lithium battery is empty (life-span is approximately 5 years), the time and date will be lost. To exchange the Lithium battery the unit has to be opened, which may only be done by a competent service authority.

## 3.2 Signal Parameters and Displays

### 3.2.1 General

In this section are described the unit specific displays, its relevant signal parameters and settings.

Generally for all modes ILS, VOR and MARKER BEACON the display is divided as shown in the following figure:

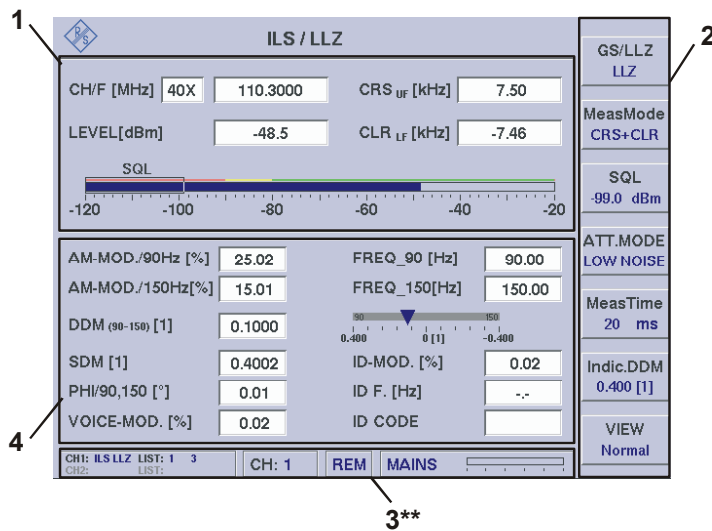

Example: ILS mode

| Item | Function                |
|------|-------------------------|
| 1    | RF Parameter section    |
| 2    | Softkeys                |
| 3    | Status display          |
| 4    | Measured values section |

#### 3.2.1.1 Status Display (3\*\*)



*In all modes the status display shows just general specific unit information exception is the mode display).*

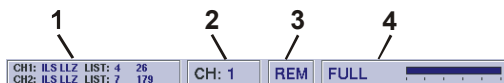

| Item | Display            | Function   | Indication  |
|------|--------------------|--|---|
| 1    | Data Logger status | Display of the Data Logger status of both measuring channels; i.e. display of the set measuring mode as well as the currently selected Data Logger list and its length (number of datasets).<br><br>A detailed description of the Data Logger can be found in section 3.14 | e.g.<br><br> |



| Item | Display                                   | Function   | Indication  |
|------|---|--|---|
| 2    | CH:                                       | Shows the measuring channel (1 / 2)<br>(channel 2 = Option)  | 1 / 2   |
| 3    | LOC / REM                                 | LOC "LOCAL"= local operation<br>REM "REMOTE"= remote operation (the function can be switched off over the button "LOC")<br>RLC "REMOTELock" = the local operation is locked by remote control (also see control command "REMOTELock")                          | LOC / REM /RLC  |
| 4    | BATTERY / CHARGE<br>FULL / EMPTY<br>MAINS | Battery display / Battery level display,<br>Charge level display of the battery,<br>Devices without the option "Battery", will be operated via an external power source.<br>Additional information can be found in section 3.1.2.1 "Battery level indication". | Bargraph<br> |

### 3.3 General Information about the Controls

Settings on the R&S® EVS 300 ILS / VOR Analyzer can be made as well with the rollkey as with the arrow buttons. An exception for the setting is the tens keyboard which can only be used for numerical settings.





#### 3.3.1 Tens keyboard

The tens keyboard is used for numerical entries into the unit. The relating edit windows can be activated either by the softkeys or by the "FREQ" button. An entry can be confirmed with the "Enter" button (e.g. the entered value is accepted) or it can be aborted with the "ESC" button. If the entry is aborted the old value is automatically reactivated. In addition, when using the "BACK" (backspace) button, the last input character can be deleted. If alphanumeric input is required, the numeric pad can be switch automatically to alpha input. The respective letter of a button is selected via a toggle switch.

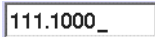

**A set receiving frequency can be confirmed as well with the "ENTER" button as with the corresponding dimension button (Hz ... GHz)!**

Example: Frequency modification

|    | Control   | Operation  | Function  |
|----|---|--|---|
| 1. |    | Press the "FREQ" (9) button.                     | Activating the frequency input, the frequency section is activated and behind the last digit the cursor appears.<br> |
| 2. |  ...  | Direct entry of the desired receiving frequency. | The frequency should be entered with the corresponding decimal place.<br>  |





|    | Control   | Operation | Function   |
|----|---|-----------|--|
| 3. |  | Confirm   | Change over to the new set frequency.<br><div style="border: 1px solid black; padding: 2px; display: inline-block;">111.2000</div> |





### 3.3.2 Rollkey

The rollkey is a universal control element for value changes and to confirm them by its push function. The rollkey can also be used for navigation purposes in the setup or in the scroll listings. To change a value the relating edit function must be active.



Example: Changing a numerical value

|    | Control   | Operation  | Function   |
|----|---|--|--|
| 1. |    | Press the "FREQ" (9) button.                         | Activating the frequency input, the frequency section is activated and behind the last digit the cursor appears.<br><div style="border: 1px solid black; padding: 2px; display: inline-block;">111.1000_</div> |
| 2. |  | Turn the rollkey until the right value is displayed. | - = value decreases<br>+ = value increases   |
| 3. |  | Confirm (rollkey push)                               | Change over to the new set frequency.<br><div style="border: 1px solid black; padding: 2px; display: inline-block;">111.2000</div>   |

Example: Setup navigation (change the Correctionfactor CH1)

|    | Control   | Operation  | Function                                      |
|----|---|--|---|
| 1. |  | Press the "Setup" (39) button.                   | Activates the setup menu.                     |
| 2. |  | Press the "Signal In" softkey                    | Switching the menu window "SignalIn Settings" |
| 3. |  | Selecting the menu point "Correctionfactor CH1". | - = move ↑<br>+ = move ↓                      |
| 4. |  | Confirm (rollkey push)                           | Now changes can be concluded.                 |









|    | Control   | Operation  | Function                                   |
|----|---|--|--|
| 5. |  | Turn the rollkey slowly to the wanted direction until the right menu point is reached. | - = value decreases<br>+ = value increases |
| 6. |  | Confirm (rollkey push)   | Acceptance of the new changes.             |



### 3.3.3 Arrow buttons

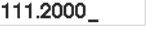

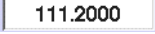

The arrow buttons are for changing values or it can for navigation in the setup. To change a value the relating edit function must be active. Always the entry must be confirmed with the "Enter" button or by pushing the rollkey.

Example: Changing a numerical value:

|    | Control  | Operation  | Function   |
|----|--|--|--|
| 1. |   | Press the "FREQ" (9) button.   | Activating the frequency input, the frequency field is highlighted in white and behind the last digit the cursor appears.<br> |
| 2. |   | Hold the arrow button depressed until the wanted value is reached.   | ↑ = value increases<br>↓ = value decreases   |
| 3. | <br> | Hold the arrow button depressed until the wanted cursor position is reached.<br>Use the up/down arrows to change the value.<br> | ← = Cursor moves to the left<br>→ = Cursor moves to the right<br>↑ = value increases<br>↓ = value decreases  |
| 4. | <br> | Press the Enter button / rollkey push.   | Change over to the new set value.<br>   |

Example: Setup navigation (change the Correctionfactor CH1)

|    | Control   | Operation                      | Function                                      |
|----|---|--------------------------------|---|
| 1. |  | Press the "Setup" (39) button. | Activates the setup menu.                     |
| 2. |  | Press the "Signal In" softkey  | Switching the menu window "SignalIn Settings" |

|    | Control   | Operation   | Function  |
|----|---|---|---|
| 3. |    | Selecting the menu point "Correctionfactor CH1".  | ↑ = Move up<br>↓ = Move down  |
| 4. |    | Press the Enter button / rollkey push.  | Now changes can be concluded.   |
| 5. | <br><br><input type="text" value="-4.0"/> | Hold the arrow button depressed until the wanted cursor position is reached.<br>Use the up/down arrows to change the value. | ⇐ = Cursor moves to the left<br>⇒ = Cursor moves to the right<br>↑ = value increases<br>↓ = value decreases |
| 6. |    | Press the Enter button / rollkey push.  | Acceptance of the new changes.  |

### 3.4 Settings in the Setup menu

#### Activates the setup menu

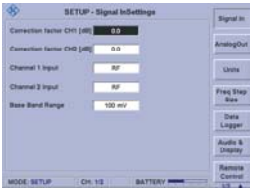
|    | Control   | Operation                      | Function   |
|----|---|--------------------------------|--|
| 1. |  | Press the "Setup" (39) button. | The R&S® EVS 300 switches over into the setup menu.<br><br> |



### 3.4.1 General

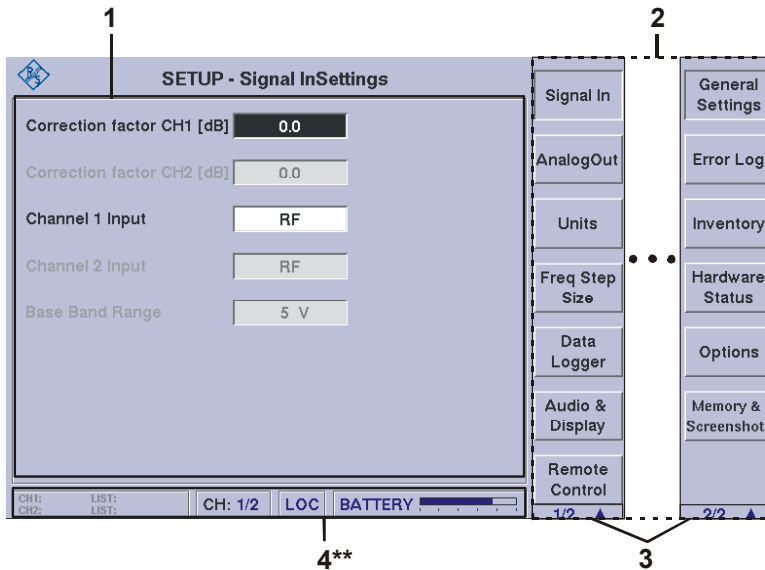

4\*\* for general description of the status field see 3.2.1.1



**Due to the multitude of settings offered, two softkey windows are available. The currently displayed softkey window will be identified with the 1/2 e.g. 2/2 ▲ -symbol (3). Use the "▲" -button to switch back and forth between the softkey windows.**

In the setup menu the following menu windows can be opened by the softkeys:

#### Menu window 1







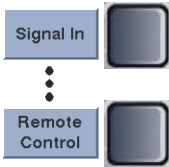
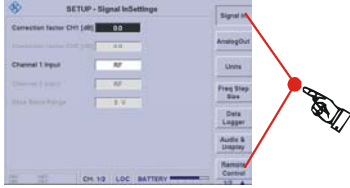

- Menu window; Signal In. (RF-Parameter setting),
- Menu window; AnalogOut (Analog parameter setting),
- Menu window; Units (Dimensions setting),
- Menu window; Freq Step Size (Frequency step width setting),
- Menu window; Data Logger (Data Logger setting),
- Menu window; Audio & Display (Display and audio setting),
- Menu window; Remote Control (LAN- and RS-232-interface setting).

#### Menu window 2

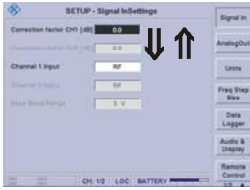



- Menu window; General Settings (Base setting of the device),
- Menu window; Error Log (Call-up the Error Log),
- Menu window; Inventory (Call-up the Inventory),
- Menu window; Hardware Status (Call-up the Hardware status),
- Menu window; Options (Call-up the optional expansions),
- Menu window; Memory & Screenshots.

**3.4.2 General operating steps in the setup menu**

The general operating steps are described below. They explain the repeating operation steps, which are necessary for navigation and setting changes. For further setup operation these steps are required.

|  | Controls  | Operation  | Function  |
|--|---|--|---|
| 1.   |    | Press the softkey to open the menu.  | The activated softkey is shown pressed.<br>   |
| 2.   |    | Navigate to the individual selection window.<br><br>- = move ↑<br>+ = move ↓                             | In the active menu window a selection window is always shown black shadowed. From here on you can navigate with the rollkey.<br><br> |
| <b>Selection window with toggle function</b> |   |  |   |
| 3.   |  | Press the Enter button / rollkey push several times (toggle function) until the right selection appears. | In this window mode the selected setting is immediately active.   |
| <b>Selection window with edit function</b>   |   |  |   |
| 4.   |  | Press the Enter button / rollkey push.   | Activates the edit function in the selection window.  |
| 5.   |  | Turn the rollkey several times until the required value appears.   | - = value decreases<br>+ = value increases  |
| 6.   |  | Press the Enter button / rollkey push.   | Acceptance of the new set value. The setting is immediately active.   |
| <b>Selection-list</b>                        |   |  |   |
| 7.   |  | Press the Enter button / rollkey push.   | Activates the selection-list.   |

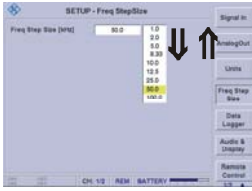

|    | Controls  | Operation  | Function   |
|----|---|--|--|
|    |   |  |  |
| 8. |  | Turn the rollkey several times until the required value appears. |  |
| 9. |  | Press the Enter button / rollkey push.                           | Acceptance of the new set value. The setting is immediately active.                |

### 3.4.3 RF Parameter setting

|    | Control   | Operation                      | Function  |
|----|---|--------------------------------|---|
| 1. |  | Press the softkey "Signal In". | Change over into the "SignalIn Settings" menu window. |

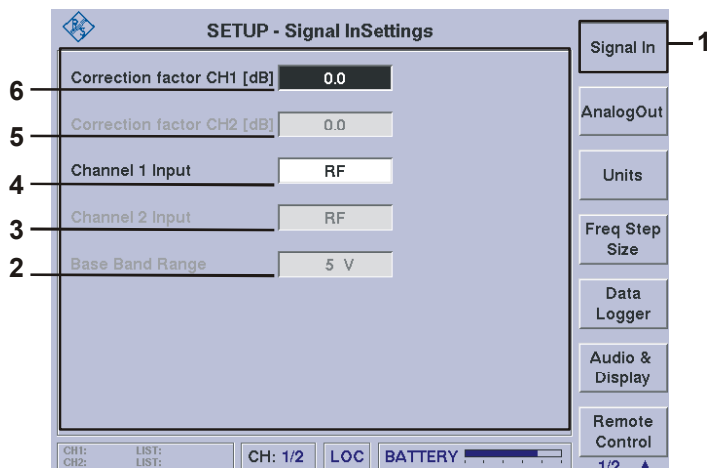



| Item | Display              | Function   | Indication     |
|------|----------------------|--|----------------|
| 2    | Base Band Range (2*) | Setting the baseband signal level (sensitivity)<br>Setting range: 500 mV / 5 V | 500 mV / 5 V   |
| 3    | Channel 2 Input (2*) | Changes between RF-input signal (CH2, 1*) or the baseband signal               | RF / Base Band |

| Item | Display                    | Function  | Indication     |
|------|----------------------------|---|----------------|
| 4    | Channel 1 Input (2*)       | Changes between RF-input signal (CH1) or the baseband signal                              | RF / Base Band |
| 5    | Correction factor CH2 [dB] | Setting of the RF attenuation at the antenna input (CH2)<br>Setting value: -20 ... +20 dB | dB             |
| 6    | Correction factor CH1 [dB] | Setting of the RF attenuation at the antenna input (CH1)<br>Setting value: -20 ... +20 dB | dB             |

1\* if channel 2 is used as an option (otherwise, not adjustable)



2\* only usable with hardware revision: RF-Board as of version 5.08, main board as of version 6.05 and software as of version 3.0. (this information may be viewed in the setup function under "inventory").

### 3.4.3.1 Setting the Antenna Correction Factor on Channel 1 / Channel 2

|    | Control   | Operation  | Function  |
|----|---|--|---|
| 1. |   | Go to the selection window "Correction factor CH1 / CH2" and activate the edit function as described in section 3.4.2. |   |
| 2. |  | Turn the rollkey several times until the required value appears.   | Setting of the antenna correction factor (gain or loss of the connected antenna, the set value will be added to the measured level) at CH1 / CH2 (1*).<br>Setting value: -20 ... +20 dB |
| 3. |  | Press the Enter button / rollkey push.   | Acceptance of the new set value.  |

1\* if channel 2 is used as an option (otherwise, not adjustable)



### 3.4.3.2 Analyse selection on Channel 1 / Channel 2

|    | Control   | Operation  | Function  |
|----|---|--|---|
| 1. |   | Go to the selection window "Channel 1 / 2 Input" and activate the edit function as described in section 3.4.2. |   |
| 2. |  | Turn the rollkey several times until the required function appears.  | Change over either to the RF input signal or to the baseband signal for further analyse of the unit.<br>Selection: RF / Base Band |
| 3. |  | Press the Enter button / rollkey push.   | Acceptance of the new set function.   |

1\* if channel 2 is used as an option (otherwise, not adjustable)



3.4.3.3 Setting the Base band signal level

|    | Control   | Operation   | Function  |
|----|---|---|---|
| 1. |   | Go to the selection window "Base band Range" as described in section 3.4.2. |   |
| 2. |  | Turn the rollkey several times until the required value appears.            | Setting the signal level (to avoid an input over modulation), of the baseband signal which is provided for analyse in the range:<br>Selection: 500 mV / 5 V |
| 3. |  | Press the Enter button / rollkey push.                                      | Acceptance of the new set value.  |

3.4.4 Settings for Analogue Output 1 / 2

|    | Control  | Operation                      | Function                                      |
|----|--|--------------------------------|---|
| 1. |  | Press the softkey "AnalogOut". | Change over into the "AnalogOut" menu window. |

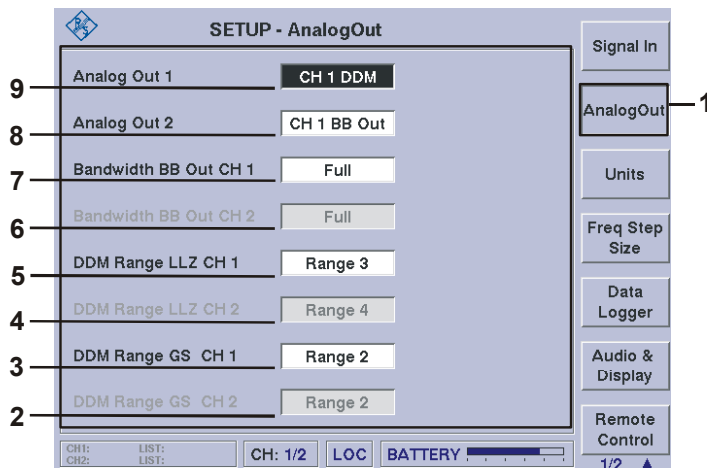



| Item | Display           | Function   | Indication    |
|------|-------------------|--|---------------|
| 2    | DDM Range GS CH2  | Scale of the XY values in Glideslope mode of the antenna input CH2 | Range 1 ... 4 |
| 3    | DDM Range GS CH1  | Scale of the XY values in Glideslope mode of the antenna input CH1 | Range 1 ... 4 |
| 4    | DDM Range LLZ CH2 | Scale of the XY values in Localizer mode of the antenna input CH2  | Range 1 ... 4 |
| 5    | DDM Range LLZ CH1 | Scale of the XY values in Localizer mode of the antenna input CH1  | Range 1 ... 4 |



| Item | Display                  | Function   | Indication  |
|------|--------------------------|--|---|
| 6    | Bandwidth BB OUT<br>CH 2 | Selection the bandwidth of the baseband signal,<br>of the antenna input CH2 (1*) | Full / Audio  |
| 7    | Bandwidth BB OUT<br>CH 1 | Selection the bandwidth of the baseband signal,<br>of the antenna input CH1      | Full / Audio  |
| 8    | Analog Out 2             | Signal selection to the analog-output 2  | CH1 DDM,<br>CH1 BB OUT,<br>CH2 DDM, (1*)<br>CH2 BB OUT (1*) |
| 9    | Analog Out 1             | Signal selection to the analog-output 1  | CH1 DDM,<br>CH1 BB OUT,<br>CH2 DDM, (1*)<br>CH2 BB OUT (1*) |

1\* if channel 2 is used as an option (otherwise, not adjustable)

#### 3.4.4.1 Setting the Analogue Out 1 / 2

|    | Control   | Operation  | Function   |
|----|---|--|--|
| 1. |   | Go to the selection window "Analog Out 1 / 2" as described in section 3.4.2. |  |
| 2. |  | Turn the rollkey several times until the required value appears.             | Signal selection between the voice signals and the XY-signals (standardized DDM-value range 1 ... 4) in relation to the receive channel.<br><br>Selection: CH1 DDM,<br>CH1 BB OUT,<br>CH2 DDM, (1*)<br>CH2 BB OUT (1*) |
| 3. |  | Press the Enter button / rollkey push.                                       | Acceptance of the new set function.  |

1\* if channel 2 is used as an option (otherwise, not adjustable)

#### 3.4.4.2 Setting the Baseband signal output CH 1 / CH 2



|    | Control   | Operation  | Function  |
|----|---|--|---|
| 1. |   | Go to the selection window "Bandwidth BB OUT CH 1 / CH 2" as described in section 3.4.2. |   |
| 2. |  | Turn the rollkey several times until the required function appears.                      | Setting the baseband signal output between the full bandwidth of the demodulator (Full, mode-dependant) or the audio range (Audio) in relation to the receiving channel CH 1 / CH 2 (1*).<br><br>Selection: Full (Demodulator band- |



|    | Control   | Operation                              | Function                              |
|----|---|--|---------------------------------------|
|    |   |  | bandwidth)<br>Audio (300 ... 3000 Hz) |
| 3. |  | Press the Enter button / rollkey push. | Acceptance of the new set function.   |



1\* if channel 2 is used as an option (otherwise, not adjustable)

### 3.4.4.3 Setting the DDM range LLZ CH 1 / CH 2

|    | Control   | Operation  | Function   |
|----|---|--|--|
| 1. |   | Go to the selection window "DDM Range LLZ CH 1 / 2" as described in section 3.4.2. |  |
| 2. |    | Turn the rollkey several times until the required function appears.                | To scale the XY-values in Localizer mode of the antenna input CH 1 / CH 2 (1*).<br>Selection: Range 1 ... 4 (2*) |
| 3. |  | Press the Enter button / rollkey push.   | Acceptance of the new set function.  |

1\* if channel 2 is used as an option (otherwise, not adjustable)

### 3.4.4.4 Setting the DDM range GS CH 1 / CH 2

|    | Control   | Operation  | Function  |
|----|---|--|---|
| 1. |   | Go to the selection window "DDM Range GS CH 1 / 2" described in section 3.4.2. |   |
| 2. |  | Turn the rollkey several times until the required function appears.            | To scale the XY-values in Glideslope mode of the antenna input CH 1 / CH 2 (1*).<br>Selection: Range 1 ... 4 (2*) |
| 3. |  | Press the Enter button / rollkey push.   | Acceptance of the new set function.   |



1\* if channel 2 is used as an option (otherwise, not adjustable)

2\*

| Range   | Localizer                       | Glideslope                     |
|---------|---------------------------------|--------------------------------|
| Range 1 | 0.0 ±0.25 DDM<br>± 0.5 V ±0.5V  | 0.0 ±0.5 DDM<br>± 0.5 V ±0.5V  |
| Range 2 | 0.0 ±0.025 DDM<br>± 0.5 V ±0.5V | 0.0 ±0.05 DDM<br>± 0.5 V ±0.5V |

|         |                                  |                                   |
|---------|----------------------------------|-----------------------------------|
| Range 3 | 0.0 ±0.0258 DDM<br>± 0.5 V ±0.5V | 0.0875 ±0.05 DDM<br>± 0.5 V ±0.5V |
| Range 4 | 0.0 ±0.5 DDM<br>± 0.5 V ±0.5V    | 0.175 ±0.05 DDM<br>± 0.5 V ±0.5V  |

### 3.4.5 Setting the Display of the Measured data

|    | Control   | Operation          | Function                                  |
|----|---|--------------------|---|
| 1. |   | Press the softkey. | Change over into the "Units" menu window. |

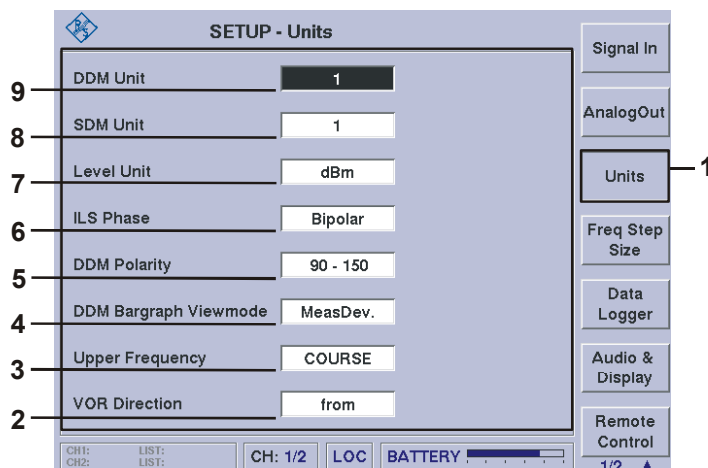



| Item | Display               | Function  | Indication                              |
|------|-----------------------|---|---|
| 2    | VOR Direction         | Setting the Bearing display in VOR mode   | from / to                               |
| 3    | Upper Frequency       | Setting in ILS mode, determining whether the upper frequency is the Coarse or the Clearance signal              | COURSE, CLEARANCE                       |
| 4    | DDM Bargraph Viewmode | Setting the ILS bargraph display:<br>MeasDev. (bargraph DDM value<br>Cockpit (bargraph at LOC FL-FR<br>GS FD-FU | MeasDev.<br>Cockpit                     |
| 5    | DDM Polarity          | Setting for the DDM polarity  | 90 – 150 / 150 - 90                     |
| 6    | ILS Phase             | Selecting the value range in the ILS phase<br>Bipolar: -60 ... 60°<br>Unipolar: 0 ... 120°                      | Bipolar / Unipolar                      |
| 7    | Level Unit            | Dimension setting for the level display reading   | dBm / dBµV                              |
| 8    | SDM Unit              | Dimension setting for the SDM display reading   | µA , % , 1<br>(1 = dimensionless value) |





| Item | Display  | Function                                      | Indication   |
|------|----------|---|--|
| 9    | DDM Unit | Dimension setting for the DDM display reading | $\mu\text{A}$ , % , 1<br>(1 = dimensionless value) |

**3.4.5.1 Setting the DDM Measuring Units**

|    | Control   | Operation  | Function   |
|----|---|--|--|
| 1. |   | Go to the selection window "DDM Unit" as described in section 3.4.2. |  |
| 2. |  | Turn the rollkey several times until the required dimension appears. | Selection of the dimension for DDM-display at the ILS mode.<br>Selection: $\mu\text{A}$ , % , 1<br>(1 = dimensionless value) |
| 3. |  | Press the Enter button / rollkey push.                               | Acceptance of the new set dimension.   |

**3.4.5.2 Setting the SDM Measuring Units**



|    | Control   | Operation  | Function   |
|----|---|--|--|
| 1. |   | Go to the selection window "SDM Unit" as described in section 3.4.2. |  |
| 2. |  | Turn the rollkey several times until the required dimension appears. | Selection of the dimension for SDM-display at the ILS mode.<br>Selection: $\mu\text{A}$ , % , 1<br>(1 = dimensionless value) |
| 3. |  | Press the Enter button / rollkey push.                               | Acceptance of the new set dimension.   |

**3.4.5.3 Setting the Level Measuring Units**



|    | Control   | Operation  | Function  |
|----|---|--|---|
| 1. |   | Go to the selection window "Level Unit" as described in section 3.4.2. |   |
| 2. |  | Turn the rollkey several times until the required dimension appears.   | Selection of the dimension for the level display.<br>Selection: $\text{dB}\mu\text{V}$ / $\text{dBm}$ |

|    | Control   | Operation                              | Function  |
|----|---|--|---|
|    |   |  | The setting will affect the level display and the bargraph in the ILS, VOR and MARKER BEACON modes. |
| 3. |  | Press the Enter button / rollkey push. | Acceptance of the new set dimension.  |

#### 3.4.5.4 Setting the values range of the ILS phase



|    | Control   | Operation   | Function   |
|----|---|---|--|
| 1. |   | Go to the selection window "ILS Phase" as described in section 3.4.2. |  |
| 2. |    | Turn the rollkey several times until the required value appears.      | Selection of the values range to the ILS phase.<br>Selection: Bipolar: -60 ... 60°<br>Unipolar: 0 ... 120° |
| 3. |  | Press the Enter button / rollkey push.                                | Acceptance of the new set values range.  |

#### 3.4.5.5 Setting the DDM polarity

|    | Control   | Operation   | Function   |
|----|---|---|--|
| 1. |   | Go to the selection window "DDM Polarity" and activate the edit function as described in section 3.4.2. |  |
| 2. |  | Turn the rollkey several times until the required value appears.  | Selection of the DDM polarity.<br>Selection: -90 - 150 / 150 - 90<br>The setting will affect the DDM display and the bargraph in the ILS mode. |
| 3. |  | Press the Enter button / rollkey push.  | Acceptance of the new set values range.  |



3.4.5.6 Setting the ILS bargraph display



|    | Control   | Operation   | Function   |
|----|---|---|--|
| 1. |   | Go to the selection window "DDM Bargraph Viewmode" as described in section 3.4.2. |  |
| 2. |  | Turn the rollkey several times until the required mode appears.                   | Selection of the bargraph display in the ILS mode. Here, a decision is made, whether the DDM indicator in ILS mode mimics the measured data (MeasDEV) or a cockpit instrument, displaying the direction of flight, which must be followed.<br><br>Selection:<br>View mode <b>MeasDev.</b><br>(bargraph DDM value)<br>or<br>View mode <b>Cockpit</b><br>(bargraph at LLZ><FL---FR<br>at GS><FD---FU |
| 3. |  | Press the Enter button / rollkey push.  | Acceptance of the new set mode.  |

3.4.6 F Step setting

|    | Control   | Operation                           | Function   |
|----|---|-------------------------------------|--|
| 1. |  | Press the softkey "Freq Step Size". | Change over into the "Freq Step Size" menu window. |



| Item | Display              | Function                            | Indication    |
|------|----------------------|-------------------------------------|---------------|
| 2    | Freq Step Size [kHz] | Setting of the frequency step width | 1 ... 100 kHz |

|    | Control   | Operation  | Function  |
|----|---|--|---|
| 2. |   | Go to the selection window "Freq Step Size" as described in section 3.4.2. |   |
| 3. |  | Turn the rollkey several times until the required value appears.           | Setting of the frequency step width in the range:<br>Setting value: 1 ... 100 kHz |
| 4. |  | Press the Enter button / rollkey push.                                     | Acceptance of the new set value.  |

### 3.4.7 Setting the Data Logger

|    | Control   | Operation                        | Function  |
|----|---|----------------------------------|---|
| 1. |  | Press the softkey "Data Logger". | Change over into the "Data Logger" menu window. |

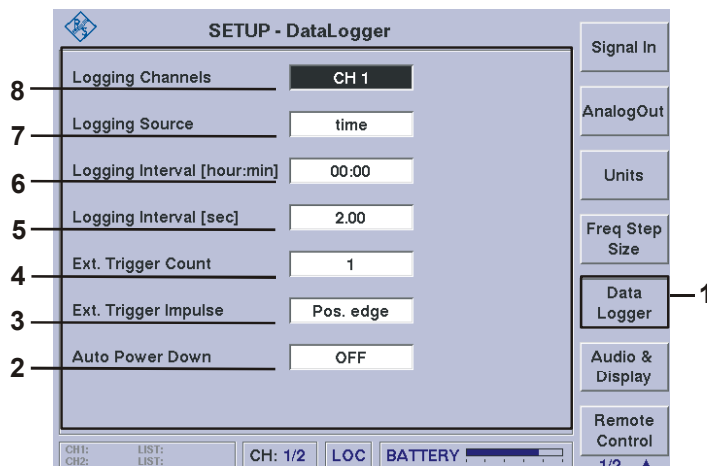

| Item | Display                     | Function   | Indication              |
|------|-----------------------------|--|-------------------------|
| 2    | Auto Power Down             | Activates the automatic ON / OFF function at a measuring interval                        | ON / OFF                |
| 3    | Ext. Trigger Impulse        | Setting the pulse edge (positive / negative) of the external trigger signal              | Pos. edge,<br>Neg. edge |
| 4    | Ext. Trigger Count          | Setting the number of external trigger signals<br>Setting range: 1 ... 1000              |                         |
| 5    | Logging Interval [sec]      | Measuring interval time setting in seconds<br>Setting value: 0.1 ... 59.90 s             | s                       |
| 6    | Logging Interval [hour:min] | Measuring interval time setting in hours and minutes<br>Setting value: 00:01 ... 24:00 h | hh:mm                   |





| Item | Display          | Function   | Indication                                  |
|------|------------------|--|---|
| 7    | Logging Source   | Setting the trigger source                                     | time,<br>ext. trigger,<br>time + ext. trig. |
| 8    | Logging Channels | Setting the receiving channel, which will be recoding the data | CH 1,<br>CH 2 (1*),<br>CH 1 + CH 2 (1*)     |

1\* if channel 2 is used as an option (otherwise, not adjustable)



A description of the required Data Logger settings can be found in section 3.14.4!

### 3.4.8 Setting the Audio- und Display characteristics

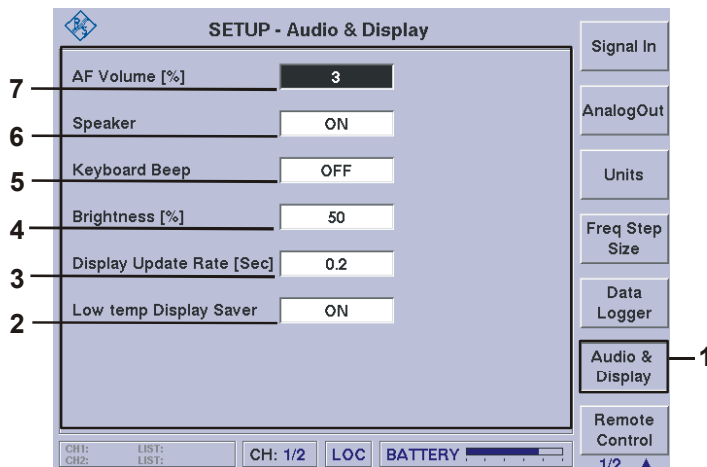

|    | Control   | Operation                            | Function  |
|----|---|--------------------------------------|---|
| 1. |   | Press the softkey "Audio & Display". | Change over into the Audio & Display menu window. |





| Item | Display                   | Function                                     | Indication  |
|------|---------------------------|--|-------------|
| 2    | Low temp Display Saver    | Switch ON / OFF the Low temp Display Saver   | ON / OFF    |
| 3    | Display Update Rate [Sec] | Setting of the display update time           | 0.1 ... 2 s |
| 4    | Brightness [%]            | Setting of the display brightness            | 0 ... 100 % |
| 5    | Keyboard Beep             | Switch ON / OFF the keyboard beeps           | ON / OFF    |
| 6    | Speaker                   | Switch ON / OFF the loudspeaker              | ON / OFF    |
| 7    | AF Volume [%]             | Setting of the AF-output level (loudspeaker) | 0 ... 100 % |





**3.4.8.1 Setting the AF Volume**

|    | Control   | Operation   | Function  |
|----|---|---|---|
| 1. |   | Go to the selection window "AF Volume" as described in section 3.4.2. |   |
| 2. |  | Turn the rollkey several times until the required value appears.      | Setting the AF-volume, this will affect the headset and loudspeaker output volume<br>Setting value: 0 ... 100 % |
| 3. |  | Press the Enter button / rollkey push.                                | Acceptance of the new set value.  |

**3.4.8.2 Setting the Display brightness**



|    | Control   | Operation  | Function   |
|----|---|--|--|
| 1. |   | Go to the selection window "Brightness" as described in section 3.4.2. |  |
| 2. |  | Turn the rollkey several times until the required value appears.       | Setting of the display brightness.<br>Setting value: 0 ... 100 % |
| 3. |  | Press the Enter button / rollkey push.                                 | Acceptance of the new set value.                                 |

**3.4.8.3 Setting the Display Update Rate**



|    | Control   | Operation   | Function  |
|----|---|---|---|
| 1. |   | Go to the selection window "Display Update Rate" as described in section 3.4.2. |   |
| 2. |  | Turn the rollkey several times until the required value appears.                | Display update rate setting (measurement values (ILS / VOR / MB mode) update in the display).<br>Setting value: 0.1 ... 2 s |
| 3. |  | Press the Enter button / rollkey push.  | Acceptance of the new set value.  |





**3.4.8.4 Setting the Keyboard Beep (ON / OFF)**

|    | <b>Control</b>  | <b>Operation</b>  | <b>Function</b>  |
|----|---|---|--|
| 1. |   | Go to the selection window "Keyboard Beep" as described in section 3.4.2. |  |
| 2. |  | Select  | ON / OFF sound of the keyboard (when pressing a button it will be confirmed with a beep sound).<br>Selection: ON / OFF |
| 3. |  | Press the Enter button / rollkey push.                                    | Acceptance of the new set function.  |

**3.4.8.5 Setting the Loudspeaker (ON / OFF)**

|    | <b>Control</b>  | <b>Operation</b>  | <b>Function</b>   |
|----|---|---|---|
| 1. |   | Go to the selection window "Speaker" as described in section 3.4.2. |   |
| 2. |  | Select  | ON / OFF sound of the loudspeaker.<br>Selection: ON / OFF |
| 3. |  | Press the Enter button / rollkey push.                              | Acceptance of the new set function.                       |

**3.4.8.6 Setting the Low temp Display Saver (ON / OFF)**

|    | <b>Control</b>  | <b>Operation</b>   | <b>Function</b>   |
|----|---|--|---|
| 1. |   | Go to the selection window "Low temp Display Saver" as described in section 3.4.2. |   |
| 2. |  | Select   | Screensaver ON / OFF function. If the screensaver is activated, the screen's back-light will be switched off between -14 to -15 °C. If the temperature raises above -14 °C, the screensaver automatically turns back on.<br>Selection: ON / OFF |
| 3. |  | Press the Enter button / rollkey push.   | Acceptance of the new set function.   |

 ***In order to prevent any damage to the display, the screensaver should always be turned on if the temperature falls below -10 °C!***

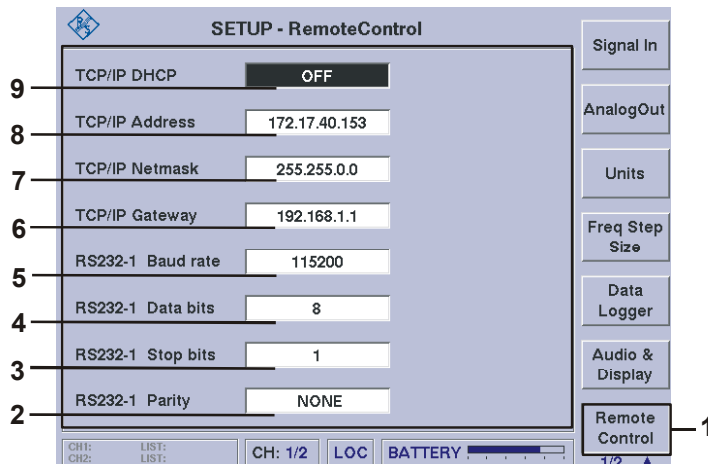

**3.4.9 Setting the Communication interface**

|    | Control   | Operation                           | Function   |
|----|---|-------------------------------------|--|
| 1. |  | Press the softkey "Remote Control". | Change over into the "Remote Control" menu window. |





| Item | Display           | Function  | Indication  |
|------|-------------------|---|---|
| 2    | RS232-1 Parity    | Setting for the Parity characteristics of the RS 232-1 remote-interface | NONE, ODD, EVEN, MARK, SPACE                                |
| 3    | RS232-1 Stop bits | Setting for the Stop bit of the RS 232-1 remote-interface               | 1, 1,5, 2   |
| 4    | RS232-1 Data bits | Setting for the Data bit of the RS 232-1 remote-interface               | 5, 6, 7, 8  |
| 5    | RS232-1 Baud rate | Setting the Baud rate of the RS 232-1 remote-interface                  | 1200, 2400, 4800, 9600, 19200, 38400, 57600, 115200, 230400 |
| 6    | TCP/IP Gateway    | Setting of the IP Gateway   | xxx.xx.xx.xxx   |
| 7    | TCP/IP Netmask    | Setting of the IP Netmask   | xxx.xxx.xxx.x   |
| 8    | TCP/IP Address    | Setting of the unit's IP-address  | xxx.xxx.xxx.x   |
| 9    | TCP/IP DHCP       | Setting of the Dynamic Host Configuration Protocol (DHCP)               | ON / OFF  |

**3.4.9.1 Setting of the Dynamic Host Configuration Protocol (DHCP)**

|    | Control   | Operation   | Function   |
|----|---|---|--|
| 1. |   | Go to the selection window "TCP/IP DHCP" as described in section 3.4.2.   |  |
| 2. |  | Select  | Using the Dynamic Host Configuration Protocol (DHCP), the dynamic configuration of the IP address will be initiated. After the activation, the IP address and the submask address will be displayed next to the selection window.<br><br>Selection: ON / OFF |
|    |   |  <b>If the Dynamic Host Configuration Protocol is used, all other protocol settings become inactive!</b> |  |
| 3. |  | Press the Enter button / rollkey push.  | Acceptance of the new set function.  |

**3.4.9.2 IP Address setting**



|    | Control   | Operation   | Function  |
|----|---|---|---|
| 1. |   | Go to the selection window "TCP/IP Address" and activate the edit function as described in section 3.4.2. |   |
| 2. |  | Enter the decimal number  | Setting of the IP address to run the unit in a LAN-network.<br><br>e.g. 172.17.40.139 |
| 3. |  | Press the Enter button / rollkey push.  | Acceptance of the new set IP address.   |

**3.4.9.3 Netmask ID setting**



|    | Control   | Operation   | Function  |
|----|---|---|---|
| 1. |   | Go to the selection window "TCP/IP Netmask" and activate the edit function as described in section 3.4.2. |   |
| 2. |  | Enter the decimal number  | Setting of the netmask ID to run the unit in a LAN-network.<br><br>e.g. 255.255.255.0 |

|    | Control   | Operation                              | Function                              |
|----|---|--|---------------------------------------|
| 3. |  | Press the Enter button / rollkey push. | Acceptance of the new set Netmask ID. |

#### 3.4.9.4 Gateway ID setting

|    | Control  | Operation   | Function  |
|----|--|---|---|
| 1. |  | Go to the selection window "TCP/IP Gateway" and activate the edit function as described in section 3.4.2. |   |
| 2. |   | Enter the decimal number  | Setting of the Gateway ID to run the unit in a LAN-network.<br>e.g. 192.168.1.1 |
| 3. |  | Press the Enter button / rollkey push.  | Acceptance of the new set Gateway ID.   |

#### 3.4.9.5 Setting the Baud rate of the Remote interface

|    | Control   | Operation   | Function  |
|----|---|---|---|
| 1. |   | Go to the selection window "RS232-1 Baud rate" as described in section 3.4.2. |   |
| 2. |  | Select  | Setting the Baud rate (Data transmission speed per second) of the RS 232-1 remote-interface.<br>Setting value: 1200 ... 230400 baud |
| 3. |  | Press the Enter button / rollkey push.  | Acceptance of the new set value.  |



#### 3.4.9.6 Setting the Data bit of the Remote interface

|    | Control   | Operation   | Function  |
|----|---|---|---|
| 1. |   | Go to the selection window "RS232-1 Data bits" as described in section 3.4.2. |   |
| 2. |  | Select  | Setting the Data bit (Number of bits per byte) of the RS 232-1 remote-interface.<br>Setting value: 5, 6, 7, 8 |





|    | Control   | Operation                              | Function                         |
|----|---|--|----------------------------------|
| 3. |  | Press the Enter button / rollkey push. | Acceptance of the new set value. |

**3.4.9.7 Setting the Stop bit of the Remote interface**

|    | Control  | Operation   | Function   |
|----|--|---|--|
| 1. |  | Go to the selection window "RS232-1 Stop bits" as described in section 3.4.2. |  |
| 2. |   | Select  | Setting of the stop bit of the RS 232-1 remote interface (during serial transfer, this enables the receiver to synchronize each transmitted character)<br>Setting value: 1, 1,5, 2 (usually 1) |
| 3. |  | Press the Enter button / rollkey push.  | Acceptance of the new set value.   |

**3.4.9.8 Setting the Parity property of the Remote interface**

|    | Control   | Operation  | Function  |
|----|---|--|---|
| 1. |   | Go to the selection window "RS232-1 Parity" as described in section 3.4.2.   |   |
| 2. |  | Select   | Setting of the parity property (error detection during data transmission, using parity checking)<br>Selection: NONE, ODD, EVEN, MARK, SPACE |
|    |   |  <p><b>NONE:</b> parity is not being sent,<br/> <b>ODD:</b> the parity bit is set to 0 / 1, this will ensure that an odd number of bits is received, which have been set to 1,<br/> <b>EVEN:</b> the parity bit is set to 0 / 1, this will ensure that an even number of bits is received, which have been set to 1,<br/> <b>MARK:</b> the parity bit is always set to 1,<br/> <b>SPACE:</b> the parity bit is always set to 0.</p> |   |
| 3. |  | Press the Enter button / rollkey push.   | Acceptance of the new set value.  |

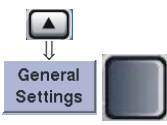

**3.4.10 Setting the General features**

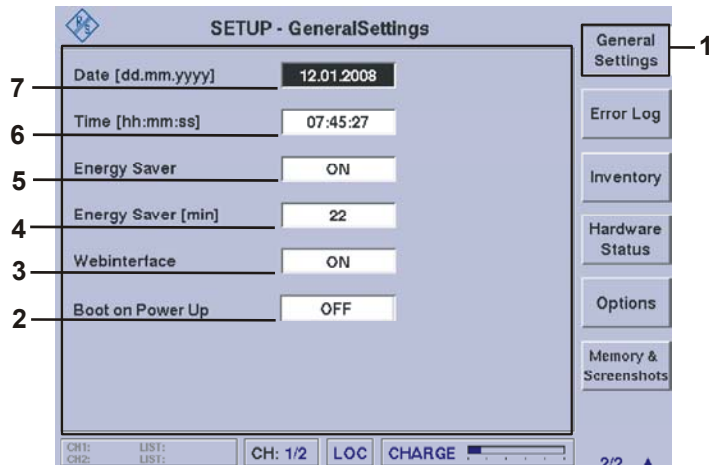
|    | Control   | Operation  | Function   |
|----|---|--|--|
| 1. |  | Switch to the second menu window of the setup function and press the softkey "General Settings". | Change over into the "General Settings" menu window. |



| Item | Display            | Function                                  | Indication   |
|------|--------------------|---|--------------|
| 2    | Boot on Power Up   | Switching on the device automatically     | ON / OFF     |
| 3    | Webinterface       | Switch ON / OFF the Web interface         | ON / OFF     |
| 4    | Energy Saver [min] | Setting of the energy saver function      | 1 ... 60 min |
| 5    | Energy Saver       | Switch ON / OFF the energy saver function | ON / OFF     |
| 6    | Time [hh:mm:ss]    | Time setting                              | hh:mm:ss     |
| 7    | Date [dd..mm.yyyy] | Date setting                              | dd.mm.yyyy   |

**3.4.10.1 Date setting**

|    | Control   | Operation   | Function  |
|----|---|---|---|
| 1. |   | Go to the selection window "Date" and activate the edit function as described in section 3.4.2. |   |
| 2. |  | Enter the date.   | Enter the date in the format shown (dd.mm.yyyy).<br>e.g. 01.01.2006 |
| 3. |  | Press the Enter button / rollkey push.  | Acceptance of the new set date.                                     |

**3.4.10.2 Time setting**

|    | Control | Operation   | Function  |
|----|---------|---|---|
| 1. |         | Go to the selection window "Time" and activate the edit function as described in section 3.4.2. |   |
| 2. |         | Enter the real time.  | Enter the time in the format shown (hh:mm:ss).<br>e.g. 08:59:00 |
| 3. |         | Press the Enter button / rollkey push.  | Acceptance of the new set time.                                 |



**3.4.10.3 Energy Saver setting (ON / OFF)**

|    | Control | Operation   | Function  |
|----|---------|---|---|
| 1. |         | Go to the selection window "Energy Saver" as described in section 3.4.2.  |   |
| 2. |         | Turn the rollkey several times until the required function appears.   | Switching the energy saver setting ON and OFF. If the energy saver setting is activated, the display will be switched off when the time set under the energy saver timer has elapsed. The collection of data is still active, only the back light has been turned off.<br>Selection: ON / OFF |
| 3. |         | Press the Enter button / rollkey push.  | Acceptance of the new set function.   |
|    |         | <b>The energy saver setting can be switched off by pressing a button or by turning the rollkey. Do not press the POWER "⏻" button (36) to turn on the display. It is the OFF button and will shut off the device!</b> |   |



**3.4.10.4 Setting the timer for the Energy Saver function**

|    | Control | Operation   | Function   |
|----|---------|---|--|
| 1. |         | Go to the selection window "Energy Saver [min]" and activate the edit function as described in section 3.4.2. |  |
| 2. |         | Turn the rollkey several times until the required value appears.  | Timer for the energy saver setting. After a preset time has elapsed, the display back-light turns itself off and can be turned back on by pressing the Enter button / rollkey push.<br>Setting value: 1 ... 60 min |





|    | Control   | Operation  | Function                              |
|----|---|--|---------------------------------------|
|    |   |  <b>Do not press the POWER "⏻" button (36) to turn on the display. It is the OFF button and will shut off the device!</b> |                                       |
| 3. |  | Press the Enter button / rollkey push.   | Acceptance of the new set time value. |

### 3.4.10.5 Switch ON / OFF the Web interface

|    | Control   | Operation  | Function  |
|----|---|--|---|
| 1. |   | Go to the selection window "Webinterface" as described in section 3.4.2. |   |
| 2. |    | Turn the rollkey several times until the required function appears.      | Switch ON / OFF the Web interface. Is the function "Webinterface ON" activated can this be called about the LAN interface about an Internet browser or about "OFF" locked.<br>Selection: ON / OFF |
| 3. |  | Press the Enter button / rollkey push.                                   | Acceptance of the new set function.   |

### 3.4.10.6 Switch ON / OFF the function "Boot on Power Up"

|    | Control   | Operation   | Function  |
|----|---|---|---|
| 1. |   | Go to the selection window "Boot on Power Up" as described in section 3.4.2.  |   |
| 2. |  | Turn the rollkey several times until the required function appears.   | Switch ON / OFF the function "Boot on Power Up". This function serves for the automatic switching on the device at add-on connection of an external supply voltage. The function only makes sense to use at device without battery. The function can be used as of the keyboard controller (KBC) software version $\geq 2.2$ .<br>Selection: ON / OFF |
|    |   |  <b>After a turning the device off a waiting time must be taken into account of switching on approx. 10 s before a repeated one automatically!</b> |   |
| 3. |  | Press the Enter button / rollkey push.  | Acceptance of the new set function.   |

**3.4.11 Call-up the Error Logbook**

*The error logbook contains only service information!*

|    | Control | Operation   | Function  |
|----|---------|---|---|
| 1. |         | Switch to the second menu screen of the setup function and press the softkey "Error Log".   | Switching to the "Error Log" menu window. General notes pertaining to the status of the device will be entered into the error logbook. In case of a malfunction, the cause of the error can be viewed here.<br><br> |
| 2. |         | With the rollkey / arrow buttons can navigate in the Error Logbook.<br><br>The entries can be deleted irrevocably over the button "ESC / Cancel"! |   |

**3.4.12 Call-up the Hardware / Software inventory list**

*The hardware / software inventory list provides information about the hardware version of the device (integrated modules, options etc.) and about the current software versions being used. This information is necessary for service purposes. Furthermore, if using a USB-memory stick (available with current software update), a software update can be processed.*

|    | Control | Operation   | Function  |
|----|---------|---|---|
| 1. |         | Switch to the second menu screen of the setup function and press the softkey "Inventory". | Switching to the "Inventory" menu window. In this hardware / software inventory list the following information is shown.<br><br><b>Hardware:</b><br>article code., serial number and revision number of the built-in modules<br><br><b>Software:</b><br>software version number. for the: |

| Control | Operation | Function  |
|---------|-----------|---|
|         |           | Release,<br>Firmware (Main),<br>Digital signal processing (DSP),<br>Keyboard-Controller (KBC) |

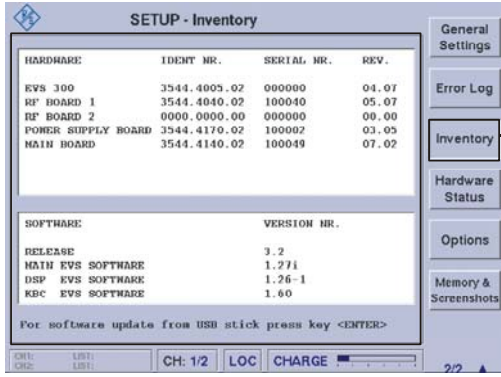
| HARDWARE           | IDENT. NR.   | SERIAL NR. | REV.  |
|--------------------|--------------|------------|-------|
| EVS 300            | 3544.4005.02 | 000000     | 04.07 |
| RF BOARD 1         | 3544.4040.02 | 100040     | 05.07 |
| RF BOARD 2         | 0000.0000.00 | 000000     | 00.00 |
| POWER SUPPLY BOARD | 3544.4170.02 | 100002     | 03.05 |
| MAIN BOARD         | 3544.4140.02 | 100049     | 07.02 |

| SOFTWARE          | VERSION NR. |
|-------------------|-------------|
| RELEASE           | 3.2         |
| MAIN EVS SOFTWARE | 1.27i       |
| DSP EVS SOFTWARE  | 1.26-1      |
| KBC EVS SOFTWARE  | 1.60        |

For software update from USB stick press key <ENTER>

### 3.4.12.1 Software Update

Click on the following website to receive the latest software update for your R&S® EVS 300 ILS / VOR analyzer:

<http://www.rohde-schwarz.com/product/evs300.html>.



*Implementation of how to update the software is described in section 5.3!*

### 3.4.13 Call-up the Device operating parameters

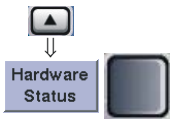

*The hardware status includes the most important device operating parameters. This may contain information about possible causes of error!*

| Control  | Operation  | Function   |
|--|--|--|
| 1.  | Press the "Setup" (1) button and change to the window 2 and press softkey "Hardware Status". | Switching to the "Hardware Status" menu window. The "Hardware Status" menu window delivers information about various test voltages of the power supply and the RF-modules.<br><br>Display "temp" indicates the current internal temperature of the device<br><br>Display "Status" indicates the sum of all test voltages |

| Control | Operation | Function |
|---------|-----------|----------|
|         |           |          |

### 3.4.14 Software options

Through the menu screen "Options", all software options, which are installed in the device may be displayed. Rohde & Schwarz offers the following software features as an option.

- F SCAN (EVS-K1: Display of the RF-frequency spectrum),
- GPS (EVS-K2: GPS mode),
- CRS|CLR (EVS-K3: ILS extension, separate Course and Clearance display),
- FFT (EVS-K4: FFT signal analysis of the baseband signal)

A licence is purchased for each respective option. The options window can be used to activate the option purchased.

| Control | Operation  | Function  |
|---------|--|---|
| 1.      | Press the "Setup" button and change to the window 2 and press softkey "Options" (1). | Switching to the "Options" menu window. This function displays the device-specific optional extensions. |

As soon as an option is activated, it will be identified as "available", otherwise, "not available" will be displayed. In addition, the device-internal MAC address of the network adapter is displayed; this information is required, since the option selection is dependant on the MAC address.

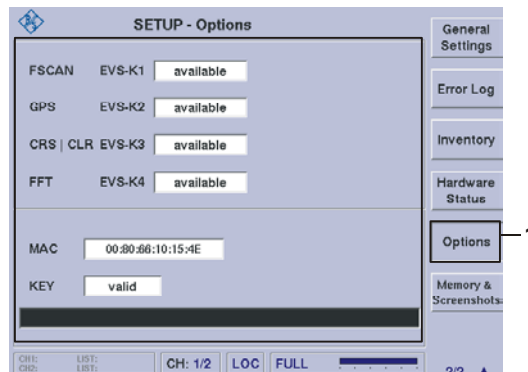



*The activation of the software option is described in Section 3.18!*

**3.4.15 Memory & Screenshots**

When using the menu screen "Memory & Screenshots", the screenshots of the EVS memory can be deleted or copied to the USB-memory stick. They will be stored in PNG-image format (Portable Network Graphics). In addition, the internal EVS-flash memory card can be re-formatted.



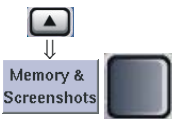
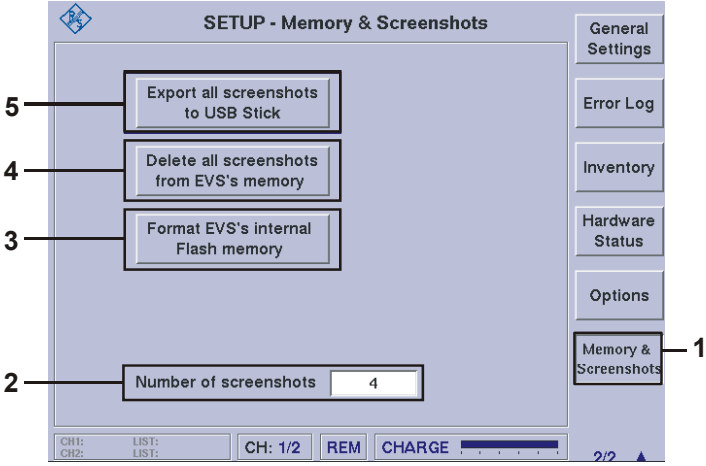

***If the EVS-Flash memory card is formatted, all screenshots and information stored on the Data Logger will be deleted!***

|    | Control   | Operation   | Function  |
|----|---|---|---|
| 1. |    | Press the "Setup" button and change to the window 2 and press softkey "Memory & Screenshots" (1).   | Switching to the "Memory & Screenshots" menu window.<br><br><br>2 - Display window, displays the total number of screenshots stored<br>3 - Function button, activates the formatting of the internal EVS flash memory card |
| 2. |  | When using the rollkey / arrow buttons, the respective function keys 3 ... 5 can be selected, and by using the Enter key, the function can be activated | Once the appropriate function has been selected, any further process can be controlled via the dialog box.  |

### 3.5 Setting of the RF-Signal Adjustment

The RF signal adjustment is available in the modes ILS, VOR, and MARKER BEACON.

|    | Control   | Operation  | Function   |
|----|---|--|--|
| 1. |  | Hold the softkey "ATT MODE" depressed until the wanted value is reached. | <p>The set mode will be updated in the softkey and is then immediately active.</p>  <p>The following modes are available:</p> <ul style="list-style-type: none"> <li>- Low-N (Low Noise, +10 dB amplification)</li> <li>- Norm (Normal, 0 dB)</li> <li>- Low-D. (Low Distortion, -25 dB attenuation)</li> <li>- Auto (automatic setting, (-25, 0, +10 dB))</li> </ul> |

By the setting in the ATT mode the RF level can be influenced individually. As shown in the block diagram corresponding signal paths will be switched for the different functions, which effects the RF signal either with an amplification (Preamplifier +10 dB), an attenuation (Attenuator -25 dB) or has no influences to the signal (Bypass). For data safety on measurement the methods of the ATT mode on the following receive levels can be used:

Low Noise: from  $< -70$  dB, Indicating range:  $-120 \dots -20$  dBm

Norm: from  $< -20$  dB, Indicating range:  $-110 \dots -10$  dBm

Low Distortion: from  $> -20$  dB, Indicating range:  $-100 \dots 20$  dBm





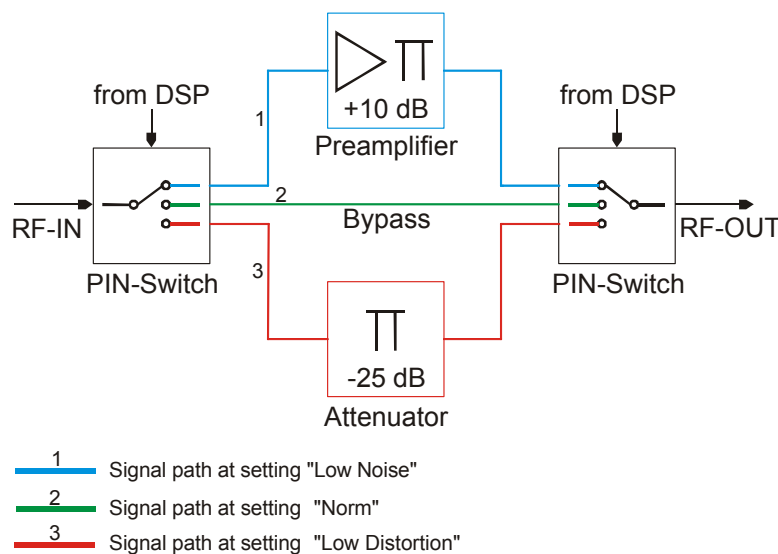

Depending on the signal level in the Auto mode automatically the correct signal path is switched.  
Indicating range:  $-120 \dots 20$  dBm

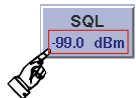

**The max. input level is +13 dBm!**

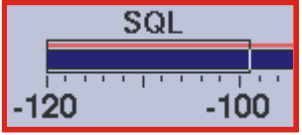

### 3.6 Setting of the Squelch Threshold

|    | Control   | Operation   | Function  |
|----|---|---|---|
| 1. |    | Press the softkey "SQL".                                      | Switching over into the edit function to set the squelch threshold. The softkey value section is active.<br><br>   |
| 2. |    | Turn the rollkey until the required squelch threshold is set. | The current squelch level will be carried along numerically in the softkey and graphically on the bargraph indicator. The green line above the bargraph marks the valid range, which is indicated in the data sheet.<br><br><br><br><br>Example representation<br><br> <b><i>If the receiving volume exceeds the preset squelch threshold, the AM-demodulated audio signal in the loudspeaker / headset will be transmitted, or otherwise turned off.</i></b> |
| 3. |  | Press the Enter button / rollkey push.                        | Acceptance of the actually set squelch threshold.<br><br>  |

### 3.7 Setting the Measurement Interval Time

Setting a measuring time interval is available in the modes ILS, VOR and MARKER BEACON. The preset measuring interval stipulates the intervals at which measurement values will be recorded, enabling an average value to be calculated.

- while in VOR and MARKER BEACON mode, max. 33.5 data / sec can be read, which approximates 30 ms / data
- while in ILS mode, max. 100.5 data / sec can be read, which approximates 10 ms / data





**While in VOR mode, 30 ms is the smallest meaningful measuring time. One unit of data / sec is approx. the same value as "MeasTime / 30 ms."**

|    | Control | Operation  | Function  |
|----|---------|--|---|
| 1. |         | Press the softkey "Meas-Time".                           | Switching over into the edit function to set the measurement time. The softkey value section is active.<br><br>   |
| 2. |         | Setting the corresponding measurement time with rollkey. | The current measurement time will be carried along numerically in the softkey.<br>Setting value: ILS, 10 ... 2000 ms (10 ms step width)<br>MB / VOR, 30 ... 2000 ms |
| 3. |         | Press the Enter button / rollkey push.                   | Acceptance of the actually set new measurement time.<br><br>  |



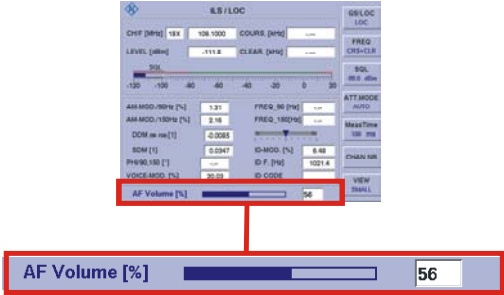

### 3.8 AF-Volume setting

|    | Control   | Operation                              | Function  |
|----|---|--|---|
| 1. |    | Press the "VOL" (43) button.           | <p>In the respective mode (e.g. ILS) the status display switches to editing function to enable the volume to be set. The change will be displayed numerically and graphically on the bargraph.</p>  |
| 2. |   | Setting the AF-volume with rollkey.    | <p>Setting of the AF-volume level at the speaker.</p> <p>Setting value: 0 ... 100 %</p>   |
| 3. |  | Press the Enter button / rollkey push. | Acceptance of the new set AF-volume level.  |



### 3.9 ILS mode operation

Activates the ILS mode

|    | Control   | Operation                   | Function  |
|----|---|-----------------------------|---|
| 1. |  | Press the "ILS" (4) button. | The R&S® EVS 300 switches over into the ILS mode.<br> |

#### 3.9.1 Signal Parameters and Display in the ILS mode

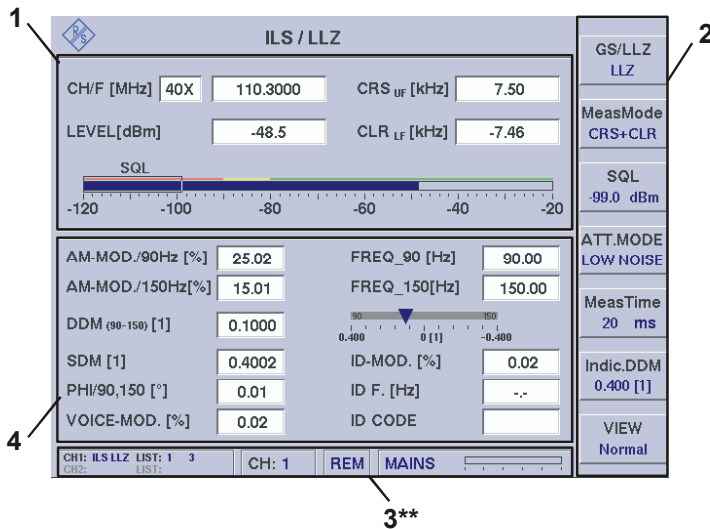

3\*\* for general description of the status field see 3.2.1.1

##### 3.9.1.1 RF Parameter Section (1)

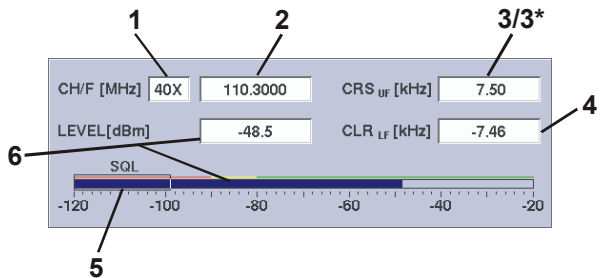

The display fields in the RF parameter field change with each setting of the measuring mode (MeasMode). The respective fields are identified with an \* and will be described in the following table, however, figures are not provided.

Example: measuring mode CRS+CLR

| Item | Display  | Function   | Indication  |
|------|--|--|---|
| 1    | CH   | Channel reading / channel setting (frequency assignment according to ICAO-frequency list)  | e.g. 22X  |
| 2    | F [MHz]  | Reading and setting of the receive frequency (receive frequency setting by channel setting according to ICAO-frequency list)   | MHz   |
| 3    | CRS <sub>UF</sub> [kHz] or CLR <sub>UF</sub> [kHz] | Display of the measured upper frequency (relative to the preset channel frequency). Which frequency shall be set as UF (upper frequency), will be determined in the setup function   | kHz   |
| 3*   | FREQ. [kHz]  | Measured deviation in relation to the preset channel frequency during the single signal measurement  | kHz   |
| 4    | CLR <sub>LF</sub> [kHz] or CRS <sub>LF</sub> [kHz] | Display of the measured lower frequency (relative to the measured channel frequency). Which frequency shall be set as LF (lower frequency), will be determined in the setup function   | dBm / dBμV  |
| 5    | SQL  | Graphic display (bargraph) of the measured level, as well as the preset squelch threshold. The green line above the bargraph marks the valid range, which is indicated in the data sheet. Information contained in the datasheet has no or only limited validity in the range identified by the red or yellow bar. | dBm / dBμV  |
| 5    | LEVEL [dBm]  | Measured receive level (numerical / bargraph) in dBm / dBμV with the settable antenna correction factor (0.0) from the setup, if this level was selected as ≠0.0.  | dBm / dBμV<br> |



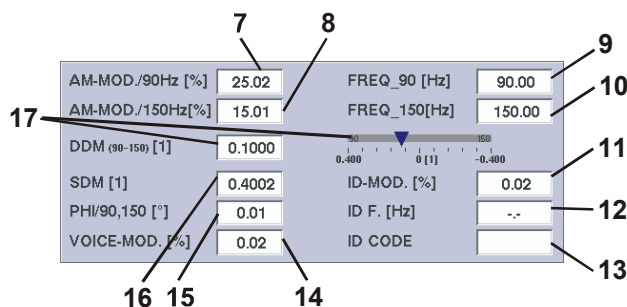



### 3.9.1.2 Measured Values Section (4)



If the softkey VIEW is used to select "Distortion", the measurement parameters in the display will change. This is further described in Section 3.9.6.1 under the heading: Measurement data field "Distortion".



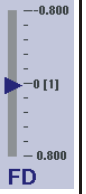

Example: normal view

| Item | Display             | Function                           | Indication |
|------|---------------------|------------------------------------|------------|
| 7    | AM-MOD./ 90 Hz [%]  | AM-modulation factor 90-Hz signal  | %          |
| 8    | AM-MOD./ 150 Hz [%] | AM-Modulation factor 150-Hz signal | %          |
| 9    | FREQ_90 [Hz]        | measured 90-Hz frequency           | Hz         |

| Item | Display          | Function   | Indication                                  |
|------|------------------|--|---|
| 10   | FREQ_150 [Hz]    | measured 150-Hz frequency  | Hz  |
| 11   | ID MOD.[%]       | Modulation factor of the Identifier  | %   |
| 12   | ID F.[Hz]        | measured frequency of the Identifier   | Hz  |
| 13   | ID CODE          | decoded identifier code  | e.g. "IKOW"                                 |
| 14   | VOICE-MOD.[%]    | AM-Modulation factor of the voice signal (in the range 300 ... 3000 Hz)  | %   |
| 15   | PHI/90,150 [°]   | Phase between 90-Hz and 150-Hz signal  | [°] degree                                  |
| 16   | SDM [1]          | Sum modulation factor as the unit 1 (absolute), $\mu$ A or percent (setup selection)   | $\mu$ A , %, 1<br>(1 = dimensionless value) |
| 17   | DDM (90-150) [1] | Difference in Depth of Modulation (DDM) (setup selection)  | $\mu$ A , %, 1<br>(1 = dimensionless value) |
|      | Bargraph         | <p>Graphic display of the DDM value, depending on the display mode (MeasDev. / Cockpit, adjustable in the setup function) and the set measuring mode LLZ / GS.</p> <p>Display mode <b>MeasDev.</b> at the measuring mode LLZ / GS:</p>  <p>Example: LLZ mode</p>  <p><b>When exceeding the indicating range the arrow turns red!</b></p> <p>Example: GS mode</p> <p>Display mode <b>Cockpit</b> (flight course indication) at the measuring mode LLZ / GS:</p> <p>Fade in: FR ("Fly Right", LLZ mode),<br/>           FL ("Fly Left", LLZ mode)<br/>           FU ("Fly Up", GS mode)<br/>           FD ("Fly Down", GS mode)</p>   <p>Example: LLZ mode</p>   <p>Example: GS mode</p> |   |

\* Measurement accuracies are given in the Technical Data!

**3.9.1.3 Softkeys (2)**

| Display  | Function   |                  |                 |                |                |                         |                         |                       |                       |
|--|--|------------------|-----------------|----------------|----------------|-------------------------|-------------------------|-----------------------|-----------------------|
| <div style="border: 1px solid black; padding: 2px; width: fit-content;">GS/LLZ<br/>LLZ</div>       | Switch over from Glideslope- / Localizer mode, set mode is shown in the softkey.   |                  |                 |                |                |                         |                         |                       |                       |
| <div style="border: 1px solid black; padding: 2px; width: fit-content;">MeasMode<br/>CRS+CLR</div> | Switch over the Course- and Clearance signal measuring, set measuring method is shown in the softkey: <ul style="list-style-type: none"> <li>- Single (Single signal measuring)</li> <li>- CRS+CLR (Course- + Clearance signal measuring)</li> <li>- CRS (Course signal measuring)</li> <li>- CLR (Clearance signal measuring)</li> <li>- CRS CLR (parallel Course- + Clearance signal measuring, option)</li> </ul>   |                  |                 |                |                |                         |                         |                       |                       |
| <div style="border: 1px solid black; padding: 2px; width: fit-content;">SQL<br/>99.0 dBm</div>     | Activates the edit function for the squelch threshold (SQL value is shown in the softkey)<br><br> <b>Setting of the squelch threshold to described in section 3.6!</b>  |                  |                 |                |                |                         |                         |                       |                       |
| <div style="border: 1px solid black; padding: 2px; width: fit-content;">ATT.MODE<br/>AUTO</div>    | Switch over of the RF-attenuation, set range is shown in the softkey: <ul style="list-style-type: none"> <li>- LOW NOISE (+10 dB),<br/>Indicating range: -120 ... -20 dBm</li> <li>- NORM (Normal, 0dB)<br/>Indicating range: -110 ... -10 dBm</li> <li>- LOW DIST (Low Distortion, -25dB)<br/>Indicating range: -100 ... 20 dBm</li> <li>- AUTO (the most favorable range will be selected automatically)<br/>Indicating range: -120 ... 20 dBm</li> </ul><br> <b>The max. input level is +13 dBm. The Setting of the RF-Signal Adjustment to described in section 3.5!</b>  |                  |                 |                |                |                         |                         |                       |                       |
| <div style="border: 1px solid black; padding: 2px; width: fit-content;">MeasTime<br/>100 ms</div>  | Activates the measurement time<br>Setting value: 10 ... 2000 ms (10 ms step width)<br><br> <b>Setting of the measurement time to described in section 3.7!</b>  |                  |                 |                |                |                         |                         |                       |                       |
| <div style="border: 1px solid black; padding: 2px; width: fit-content;">Indic.DDM<br/>40 %</div>   | Scaling of the DDM bargraph (Setting the units of measure in the setup function)<br>Setting range: <table border="1" style="width: 100%; border-collapse: collapse;"> <thead> <tr> <th style="text-align: left;">Glideslope mode:</th> <th style="text-align: left;">Localizer mode:</th> </tr> </thead> <tbody> <tr> <td>80%, 15%, 7.5%</td> <td>40%, 15%, 7.5%</td> </tr> <tr> <td>0.800, 0.150, 0.075 [1]</td> <td>0.400, 0.150, 0.075 [1]</td> </tr> <tr> <td>800 μA, 150 μA, 75 μA</td> <td>400 μA, 150 μA, 75 μA</td> </tr> </tbody> </table><br> <b>Starting with software release 3.1, scaling of the DDM bargraph is possible. In previous versions, the softkey function "CHAN NR" is active instead.</b> | Glideslope mode: | Localizer mode: | 80%, 15%, 7.5% | 40%, 15%, 7.5% | 0.800, 0.150, 0.075 [1] | 0.400, 0.150, 0.075 [1] | 800 μA, 150 μA, 75 μA | 400 μA, 150 μA, 75 μA |
| Glideslope mode:   | Localizer mode:  |                  |                 |                |                |                         |                         |                       |                       |
| 80%, 15%, 7.5%   | 40%, 15%, 7.5%   |                  |                 |                |                |                         |                         |                       |                       |
| 0.800, 0.150, 0.075 [1]  | 0.400, 0.150, 0.075 [1]  |                  |                 |                |                |                         |                         |                       |                       |
| 800 μA, 150 μA, 75 μA  | 400 μA, 150 μA, 75 μA  |                  |                 |                |                |                         |                         |                       |                       |
| <div style="border: 1px solid black; padding: 2px; width: fit-content;">VIEW<br/>Normal</div>      | Switch over between Normal- / Distortion- / Large views, set mode is shown in the softkey: <ul style="list-style-type: none"> <li>- Normal (normal view)</li> <li>- Distortion (distortion view)</li> <li>- Large (zoom view)</li> </ul>   |                  |                 |                |                |                         |                         |                       |                       |



3.9.2 Setting the Receiving frequency in the ILS mode



ILS-Localizer: 108 ... 112 MHz  
ILS-Glideslope: 329 ... 335 MHz (Preselector filter 320 ... 340 MHz)

|    | Control | Operation  | Function  |
|----|---------|--|---|
| 1. |         | Press the "FREQ" (9) button.   | Behind the last digit the cursor appears.<br>   |
| 2. |         | Setting the corresponding frequency with rollkey / keyboard.                 | Enter the frequency, including the appropriate decimal places. If the frequency corresponds with a defined channel (ICAO frequency list, 3.9.3.1), then the channel number will be shown in the channel display window; otherwise dashes will be shown.<br> |
| 3. |         | Confirm with the correct dimension or Press the Enter button / rollkey push. | Acceptance of the new set frequency.<br>  |

NOTES



1) On frequency input the complete frequency range (70 ... 350 MHz) can be entered independent from the mode. However, the data content is only given at mode specific frequency ranges:

ILS-Localizer: 108 ... 112 MHz  
ILS-Glideslope: 329 ... 335 MHz (Preselector filter 320 ... 340 MHz)







With the "ESC" button any time a break off of the function is possible and the old value will be restored!

As of SW release 3.2 you change when setting a frequency within the Localizer or Glideslope frequency range into the corresponding mode LLZ or GS automatically.

2) If the frequency setting will be performed with the rollkey or the cursor buttons, the corresponding target channels will be displayed according to the ICAO frequency list in the channel window.

3) The frequency step width (0,001 ... 10,000 MHz) is settable in the setup (F-Step) when using the rollkey or the cursor buttons.

**3.9.3 Setting the Receiving channel in the ILS mode**

|    | Control  | Operation  | Function  |
|----|--|--|---|
| 1. |   | Press (2x) the "FREQ" (9) button.  | Switching over into the edit function for channel input (frequency assignment according to ICAO-frequency list, 3.9.3.1). The channel section is activated and behind the last digit the cursor appears.<br><br> |
| 2. |   | Use the rollkey / keyboard to set the respective channel number and use the up / down arrows to set X or Y | Only digits entry. (see also ILS-frequency / channel list). The frequency (ICAO frequency list, 3.9.3.1) associated with the channel will be displayed in the frequency field<br><br>                            |
| 3. |  | Press the Enter button / rollkey push.   | Acceptance of the new set channel no.<br><br>   |

**NOTES**

- 1) **On channel input via the tens keyboard the mode specific channel ranges must be observed:**

**Localizer / Glideslope: 18X ... 56Y  
(channel no. Assignment is identical)**

**When the channel ranges are exceeded or when they fall below, the digits in the frequency section will be displayed in red and they cannot be used!**

- 2) **With the "ESC" button any time a break off of the function is possible and the old value will be restored!**
- 3) **If the frequency setting will be performed with the rollkey or the cursor buttons, the corresponding frequencies will be displayed during setting!**



**3.9.3.1 ILS-Channel Frequency list**

| <b>ICAO Channel</b> | <b>Localizer mode Frequency (MHz)</b> | <b>Glideslope mode Frequency (MHz)</b> |
|---------------------|---------------------------------------|--|
| 18X                 | 108.10                                | 334.70                                 |
| 18Y                 | 108.15                                | 334.55                                 |
| 20X                 | 108.30                                | 334.10                                 |
| 20Y                 | 108.35                                | 333.95                                 |
| 22X                 | 108.50                                | 329.90                                 |
| 22Y                 | 108.55                                | 329.75                                 |
| 24X                 | 108.70                                | 330.50                                 |
| 24Y                 | 108.75                                | 330.35                                 |
| 26X                 | 108.90                                | 329.30                                 |
| 26Y                 | 108.95                                | 329.15                                 |
| 28X                 | 109.10                                | 331.40                                 |
| 28Y                 | 109.15                                | 331.25                                 |
| 30X                 | 109.30                                | 332.00                                 |
| 30Y                 | 109.35                                | 331.85                                 |
| 32X                 | 109.50                                | 332.60                                 |
| 32Y                 | 109.55                                | 332.45                                 |
| 34X                 | 109.70                                | 333.20                                 |
| 34Y                 | 109.75                                | 333.05                                 |
| 36X                 | 109.90                                | 333.80                                 |
| 36Y                 | 109.95                                | 333.65                                 |
| 38X                 | 110.10                                | 334.40                                 |
| 38Y                 | 110.15                                | 334.25                                 |
| 40X                 | 110.30                                | 335.00                                 |
| 40Y                 | 110.35                                | 334.85                                 |
| 42X                 | 110.50                                | 329.60                                 |
| 42Y                 | 110.55                                | 329.45                                 |
| 44X                 | 110.70                                | 330.20                                 |
| 44Y                 | 110.75                                | 330.05                                 |
| 46X                 | 110.90                                | 330.80                                 |
| 46Y                 | 110.95                                | 330.65                                 |
| 48X                 | 111.10                                | 331.70                                 |
| 48Y                 | 111.15                                | 331.55                                 |
| 50X                 | 111.30                                | 332.30                                 |
| 50Y                 | 111.35                                | 332.15                                 |
| 52X                 | 111.50                                | 332.90                                 |
| 52Y                 | 111.55                                | 332.75                                 |
| 54X                 | 111.70                                | 333.50                                 |
| 54Y                 | 111.75                                | 333.35                                 |
| 56X                 | 111.90                                | 331.10                                 |
| 56Y                 | 111.95                                | 330.95                                 |



### 3.9.4 Selection the Localizer / Glideslope mode

This function determines which area (LLZ / GS) of the ground-based instrument landing system (ILS) should be checked. A selection will be made whether the Localizer (LLZ) or the Glideslope (GS) should be measured. The respective measurement parameters will be shown in a mode-specific display.



|    | Control   | Operation                     | Function  |
|----|---|-------------------------------|---|
| 1. |  | Press the softkey "GS / LLZ". | Switching over between Glideslope and Localizer mode, the current mode is shown in the softkey.<br><br><br>Selection: GS / LLZ |



*The previously selected receiving channel will be maintained during mode switch-over, however, the frequency will be changed per ICAO frequency list. As of SW release 3.2 you change when setting a frequency within the Localizer or Glideslope frequency range into the corresponding mode LLZ or GS automatically.*

### 3.9.5 Switch over the Display view in the ILS mode

This function enables the display to be switched between normal- and large views. In the large view, the most important parameters of a mode are displayed extra large, enabling them to be read from a large distance. The view "Distortion" comprises all measurement parameters for the determination of the distortion factors for the 90 / 150 Hz signal in the Localizer / Glideslope mode. Channel number / frequency, as well as the use of the softkey are still available during the large function.

|    | Control   | Operation  | Function  |
|----|---|--|---|
| 1. |  | Hold the softkey "View" depressed until the wanted display is set. | Switch over between Normal- / Distortion- / Large views, set mode is shown in the softkey.<br><br><br>Example: Select "Normal" view.<br>Selection: Normal (normal view)<br>Distortion (view distortion)<br>Large (zoom view) |

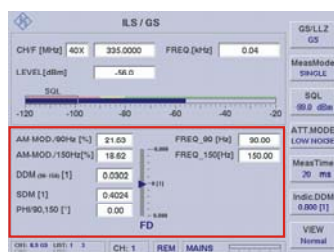

normal view

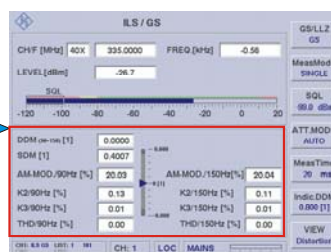

view distortion

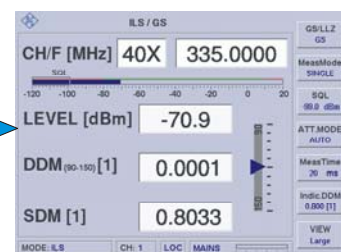



zoom view (large)



3.9.6 Processing Distortion measurements in ILS mode

Distortion measurements are used to evaluate the quality of the received ILS signals. The measurements provide information about not-so-ideal characteristics (non-linear properties) of the Localizer's and Glideslope's transmitter. The modulation of the 2<sup>nd</sup> and 3<sup>rd</sup> order will be measured selectively and the "Total Harmonic Distortion" (THD) will be determined. The THD-value specifies the ratio between the modulation's power and the power of the wanted signal plus the modulation. When determining the THD value, harmonic waves up the 4<sup>th</sup> order are considered.

|    | Control   | Operation   | Function  |
|----|---|---|---|
| 1. |  | Hold the softkey "View" depressed until the distortion view is set. | The display switches to the ILS distortion function, the current mode is shown in the softkey.<br><br> |

The view "Distortion" contains all measurement parameters for the determination of the distortion factors for the 90 / 150 Hz signal in the Localizer / Glideslope mode.

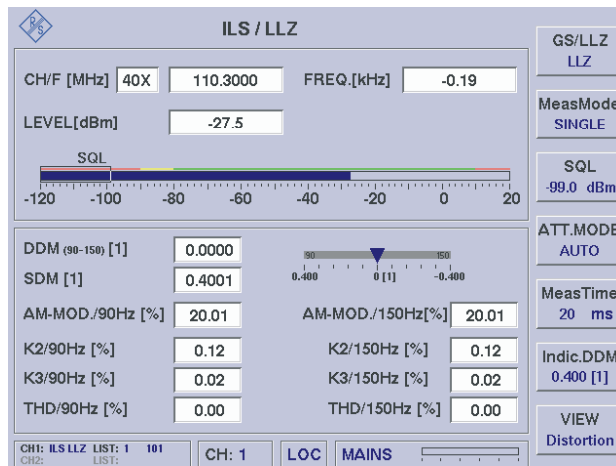

Example: View "Distortion" ILS / LLZ



**While in the "CRS|CLR" measuring mode, distortion measurements are not possible!**

### 3.9.6.1 Measured Values Section (4) of the ILS Distortion view



*The following only describes the differences between the data displays "Distortion" vs. ILS view "Normal".*

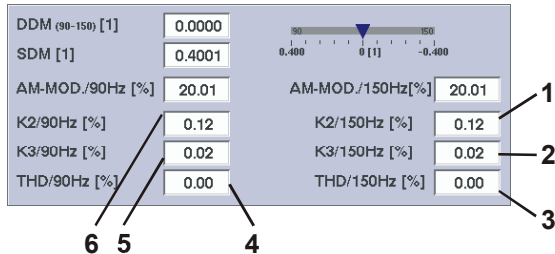

Example: View "Distortion" ILS / LLZ



| Item | Display        | Function  | Indication |
|------|----------------|---|------------|
| 1    | K2/150 Hz [%]  | distortion 2 <sup>rd</sup> order, 150-Hz signal | %          |
| 2    | K3/150 Hz [%]  | distortion 3 <sup>rd</sup> order, 150-Hz signal | %          |
| 3    | THD/150 Hz [%] | Total Harmonic Distortin (THD), 150-Hz signal   | %          |
| 4    | K2/90 Hz [%]   | distortion 2 <sup>rd</sup> order, 90-Hz signal  | %          |
| 5    | K3/90 Hz [%]   | distortion 3 <sup>rd</sup> order, 90-Hz signal  | %          |
| 6    | THD/90 Hz [%]  | Total Harmonic Distortin (THD), 90-Hz signal    | %          |

### 3.9.7 ILS measurement modes

In order to perform a differentiated signal analysis of the Course and Clearance signal while in ILS mode, the following measurement modes are available:

- Single (Single signal measuring)
- Course and Clearance signal measuring (CRS+CLR)
- Course signal measuring (CRS)
- Clearance signal measuring (CLR)
- parallel Course- + Clearance signal measuring (CRS|CLR)

#### Select a measurement mode

|    | Control   | Operation  | Function  |
|----|---|--|---|
| 1. |  | Hold the softkey "MeasMode" depressed until the measurement mode is set. | The display switches to the Course and Clearance signal measuring, the current mode is shown in the softkey.<br><br><br>Example: Course and Clearance signal measuring |



*The following sections describe the operation and the technical features of the individual measurement modes.*



### 3.9.7.1 Single signal measuring

The function Single signal measurement measures the preset channel frequency on the narrow band. The nominal width of the filter band is 12.4 kHz ( $\pm 0.1$  dB); the measured deviation in relation to the preset frequency will be displayed in kHz in the frequency field.

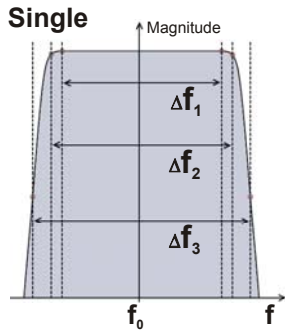

| Filter curves Single signal measuring |                                 |          |
|---------------------------------------|---------------------------------|----------|
| $\Delta f_1$                          | Filter flatness (ripple <0.1dB) | 12.4 kHz |
| $\Delta f_2$                          | -3 dB bandwidth                 | 14.8 kHz |
| $\Delta f_3$                          | -60 dB stop band attenuation    | 18.8 kHz |

#### 3.9.7.1.1 Select the Single signal measuring mode

|    | Control | Operation   | Function   |
|----|---------|---|--|
| 1. |         | Hold the softkey "MeasMode" depressed until the "Single" measurement mode is set. | The display switches to the Single signal measuring, the current mode is shown in the softkey:<br><br> |

The deviation with respect to the preset channel frequency is shown in the display field frequency (1).

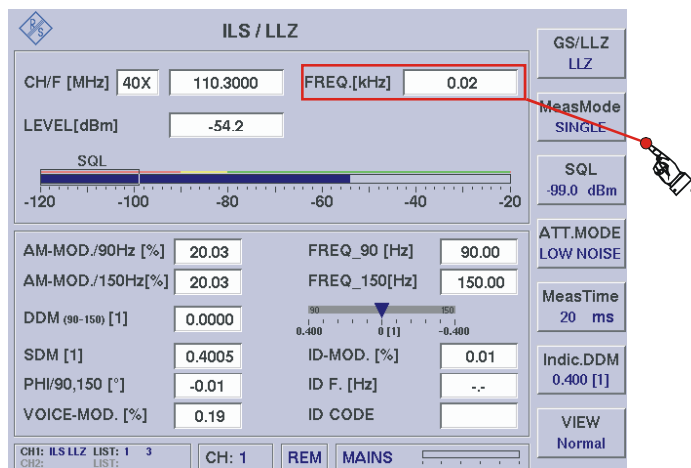

### 3.9.7.2 Course and Clearance Signal measuring

The Course and Clearance signal measuring analyses the ILS dual frequency systems, whereby one signal lies slightly above and the second signal slightly below the nominal channel frequency. In order to capture both signals simultaneously, measurements are taken on a broadband, using the preset receiving frequency. The filterbandwidth (CRS+CLR) is 32.0 kHz ( $\pm 0.1$  dB) nominal.

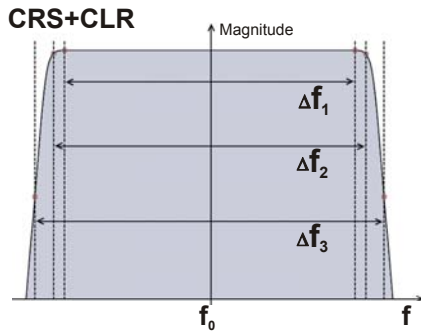

| Filter bandwidths CRS+CLR signal measuring |                                 |          |
|--|---------------------------------|----------|
| $\Delta f_1$                               | Filter flatness (ripple <0.1dB) | 32.0 kHz |
| $\Delta f_2$                               | -3 dB bandwidth                 | 34.9 kHz |
| $\Delta f_3$                               | -60 dB stop band attenuation    | 39.1 kHz |

#### 3.9.7.2.1 Select the Course and Clearance signal measuring

| Control | Operation  | Function   |
|---------|--|--|
| 1.      | Hold the softkey "MeasMode" depressed until the "CRS+CLR" measurement mode is set. | The display switches to the Course and Clearance signal measuring, the current mode is shown in the softkey: |

While in "CRS+CLR" measuring mode, both Course and Clearance frequencies are displayed simultaneously. Furthermore, while in the setup function "Units", a selection may be made, whether to receive the Course or the Clearance signal along the upper frequency (UF); consequently, depending on the selection, the other signal will therefore be assigned to the lower frequency (LF).

**Setup: upper frequency = COURSE**

- CRS = UF (upper frequency)
- CRS UF [kHz] 7.50
- CLR LF [kHz] -7.46
- CLR = LF (lower frequency)

**Setup: upper frequency = CLEARANCE**

- CLR = UF (upper frequency)
- CLR UF [kHz] 7.50
- CRS LF [kHz] -7.46
- CRS = LF (lower frequency)

**When measuring the level in CRS+CLR mode, only those parts of a signal will be considered, which lie within the separation filters for CRS and CLR**



(see filter diagrams in Section 3.9.7.3). Therefore, the level of a single signal, which coincides precisely with the channel frequency, will not be displayed correctly!

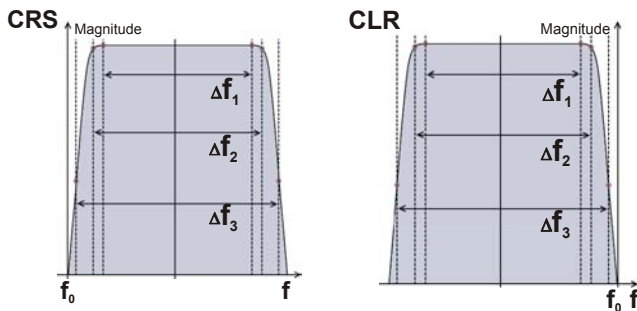

### 3.9.7.3 Separate measurements of Course or Clearance signals

While in CRS and CLR mode, the respective signal will be filtered, demodulated and analyzed on its own. The nominal filter bandwidth is 12.4 kHz ( $\pm 0.1$  dB) with a capacity (at filter center) of  $\pm 10$  kHz of the preset channel frequency.



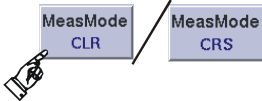

| Filter bandwidths CRS/CLR signal measuring |                                 |          |
|--|---------------------------------|----------|
| $\Delta f_1$                               | Filter flatness (ripple <0.1dB) | 12.4 kHz |
| $\Delta f_2$                               | -3 dB bandwidth                 | 14.8 kHz |
| $\Delta f_3$                               | -60 dB stop band attenuation    | 18.8 kHz |

#### 3.9.7.3.1 Select the "CRS" or "CLR" measuring mode

|    | Control  | Operation   | Function   |
|----|--|---|--|
| 1. | <br> | Hold the softkey "MeasMode" depressed until the "CRS" or "CLR" measurement mode is set. | The display switches to the Course or Clearance signal measuring, the current mode is shown in the softkey:<br> |

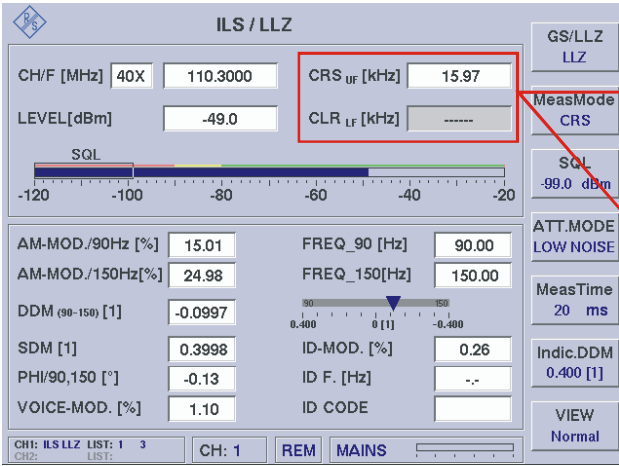
In the set measuring mode "CRS" or "CLR", the respective Course or Clearance frequency will be shown. The display of the measurement mode, which is not active, will be dimmed gray. Furthermore, while in the setup function "Units", a selection may be made, whether to receive the Course or the Clearance signal along the upper frequency (UF); consequently, depending on the selection, the other signal will therefore be assigned to the lower frequency (LF).

| Control | Operation   | Function  |
|---------|---|---|
|         |  |  |

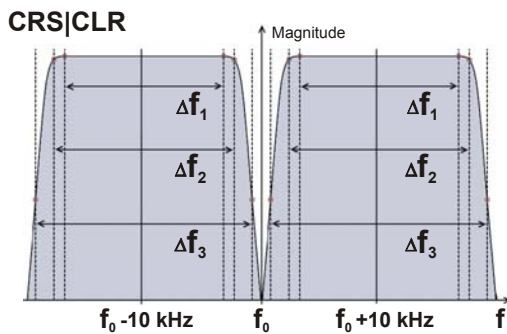

### 3.9.7.4 Parallel Course and Clearance signal measuring (Option EVS-K3)

While in the function CRS|CLR (parallel Course and Clearance display - optional feature), both the Course and Clearance signal will be demodulated and analyzed simultaneously, however separate from each other. In addition, the sum signal (corresponds with the CRS+CLR mode) will be demodulated and analyzed.



| Filter bandwidths CRS CLR signal measuring |                                   |          |
|--|-----------------------------------|----------|
| $\Delta f_1$                               | Filter flatness (ripple < 0.1 dB) | 12.4 kHz |
| $\Delta f_2$                               | -3 dB bandwidth                   | 14.8 kHz |
| $\Delta f_3$                               | -60 dB stop band attenuation      | 18.8 kHz |

#### 3.9.7.4.1 Select the CRS|CLR measuring mode

| Control  | Operation  | Function   |
|--|--|--|
| 1.  | Hold the softkey "MeasMode" depressed until the "CRS CLR" measurement mode is set. | The display switches to the parallel Course or Clearance signal measuring, the current mode is shown in the softkey:  |



| Control | Operation | Function |
|---------|-----------|----------|
|---------|-----------|----------|

In addition, a frequency / channel change can be performed the same way as in "Normal" view.

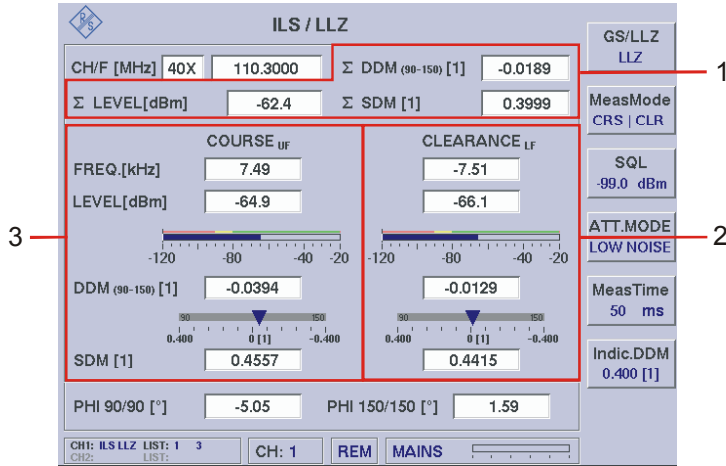

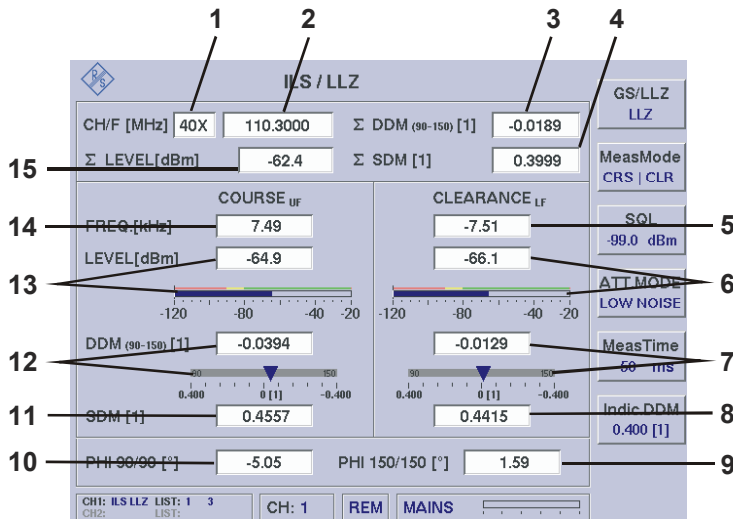

- 1 - Indication of the sum signal's parameters
- 2 - Indication of the Course signal's
- 3 - Indication of the Clearance signal's

**3.9.7.4.2 Signal Parameters and Display in the CRS|CLR window (Option)**



| Item | Display | Function   | Indication |
|------|---------|--|------------|
| 1    | CH      | Channel reading / channel setting (frequency assignment according to ICAO-frequency list)                                    | e.g. 40X   |
| 2    | F [MHz] | Reading and setting of the receive frequency (receive frequency setting by channel setting according to ICAO-frequency list) | MHz        |



| Item | Display                 | Function   | Indication  |
|------|-------------------------|--|---|
| 3    | $\sum$ DDM (90-150) [1] | DDM value of the sum signal (CRS+CLR)<br>(Setting of the units in the setup)   | $\mu\text{A}$ , %, 1<br>(1 = dimensionless value) |
| 4    | $\sum$ SDM [1]          | SDM value of the sum signal (CRS+CLR)<br>(Setting of the units in the setup)   | $\mu\text{A}$ , %, 1<br>(1 = dimensionless value) |
| 5    | FRQ. [kHz]              | Display of the measured Clearance / Course LF frequency (3*) relative to the measured channel frequency.   | kHz   |
| 6    | LEVEL [dBm]             | Measured receive level of the Clearance / Course LF signals (3*), numerical / bargraph) in dBm / dB $\mu$ V (setup selection)  | dBm / dB $\mu$ V                                  |
| 7    | DDM (90-150) [1]        | Measured Difference in Depth of Modulation (DDM) of the Clearance / Course LF signals (3*). (Setting of the units in the setup)  | $\mu\text{A}$ , %, 1<br>(1 = dimensionless value) |
|      | Bargraph                | <p>Graphic display of the DDM value of the measured Clearance / Course LF signal (3*) depends on the display mode MeasDev. / Cockpit, setup selection) and the preset measurement mode LLZ / GS.</p> <p><i>The bargraph is omitted in measurement mode "GS"</i></p> <p>Display mode <b>MeasDev.</b> at the measuring mode LLZ:</p>  <p><b>When exceeding the indicating range the arrow turns red!</b></p> <p>Example: LLZ mode</p> <p>Display mode <b>Cockpit</b> (flight course indication) at the measuring mode LLZ:<br/>           Fade in: FR (Fly Right),<br/>           FL (Fly Left)</p>  <p><b>When exceeding the indicating range the arrow turns red!</b></p> <p>Example: LLZ mode</p> |   |
| 8    | SDM [1]                 | Measured Sum of Modulation (SDM) of the Clearance / Course LF signals (3*).<br>(Setting of the units in the setup)   | $\mu\text{A}$ , %, 1<br>(1 = dimensionless value) |
| 9    | PHI 150/150 [°]         | Phase between the two 150-Hz signals of the measured Course and Clearance LF signals (3*).   | [°] degree  |
| 10   | PHI 90/90 [°]           | Phase between the two 90-Hz signals of the measured Course and Clearance LF signals (3*).  | [°] degree  |
| 11   | SDM [1]                 | Measured Sum of Modulation (SDM) of the Clearance / Course UF signals (4*).<br>(Setting of the units in the setup)   | $\mu\text{A}$ , %, 1<br>(1 = dimensionless value) |
| 12   | DDM (90-150) [1]        | Measured Difference in Depth of Modulation (DDM) of the Clearance / Course UF signals (4*). (Setting of the units in the setup)  | $\mu\text{A}$ , %, 1<br>(1 = dimensionless value) |



| Item | Display              | Function   | Indication       |
|------|----------------------|--|------------------|
|      | Bargraph             | Graphic display of the DDM value of the measured Clearance / Course UF signal (4*), otherwise, same as Item 7.   |                  |
| 13   | LEVEL [dBm]          | Measured receive level of the Clearance / Course UF signals (4*), numerical / bargraph) in dBm / dB $\mu$ V (setup selection)                                    | dBm / dB $\mu$ V |
| 14   | FRQ. [kHz]           | Display of the measured Clearance / Course UF frequency (4*) relative to the measured channel frequency.   | kHz              |
| 15   | $\Sigma$ LEVEL [dBm] | The sum of the single levels of Course and Clearance signal. Only these signal parts will be considered, which lie within the separation filter for CRS and CLR. | dBm / dB $\mu$ V |



\* Measurement accuracies are given in the Technical Data!

3\* LF = lower frequency

4\* UF = upper frequency

### 3.10 VOR mode operation

Activates the VOR mode

|    | Control   | Operation                   | Function  |
|----|---|-----------------------------|---|
| 1. |  | Press the "VOR" (6) button. | The R&S® EVS 300 switches over into the VOR mode.<br><br> |

#### 3.10.1 Signal Parameters and Display in the VOR mode

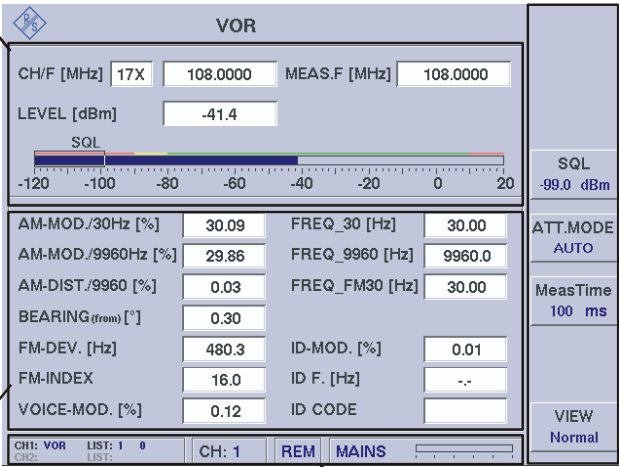

The screenshot shows the VOR mode interface with the following parameters and controls:

- 1:** R&S logo in the top left corner.
- 2:** The right-hand side of the interface containing:
  - SQL: -99.0 dBm
  - ATT.MODE: AUTO
  - MeasTime: 100 ms
  - VIEW: Normal
- 3\*\*:** The status bar at the bottom showing: CH: 1 REM MAINS
- 4:** The main parameter table on the left side of the interface.

| VOR                            |       |                |                       |
|--------------------------------|-------|----------------|-----------------------|
| CH/F [MHz]                     | 17X   | 108.0000       | MEAS.F [MHz] 108.0000 |
| LEVEL [dBm]                    | -41.4 |                |                       |
| SQL                            |       |                |                       |
| -120 -100 -80 -60 -40 -20 0 20 |       |                |                       |
| AM-MOD./30Hz [%]               | 30.09 | FREQ_30 [Hz]   | 30.00                 |
| AM-MOD./9960Hz [%]             | 29.86 | FREQ_9960 [Hz] | 9960.0                |
| AM-DIST./9960 [%]              | 0.03  | FREQ_FM30 [Hz] | 30.00                 |
| BEARING <sub>(from)</sub> [°]  | 0.30  |                |                       |
| FM-DEV. [Hz]                   | 480.3 | ID-MOD. [%]    | 0.01                  |
| FM-INDEX                       | 16.0  | ID.F. [Hz]     | -.-                   |
| VOICE-MOD. [%]                 | 0.12  | ID CODE        |                       |

3\*\* for general description of the status field see 3.2.1.1



**3.10.1.1 RF Parameter Section (1)**

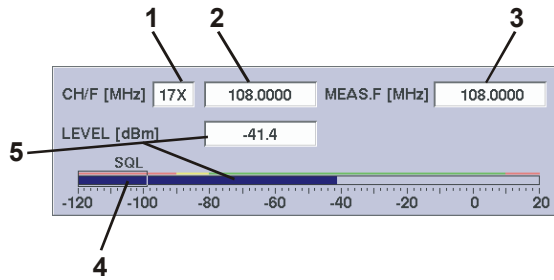

| Item | Display       | Function   | Indication  |
|------|---------------|--|---|
| 1    | CH/F [MHz]    | Channel reading / channel setting (frequency assignment according to ICAO-frequency list)  | z.B. 38X  |
| 2    | CH/F [MHz]    | Reading and setting of the receive frequency (receive frequency setting by channel setting according to ICAO-frequency list)   | MHz   |
| 3    | MEAS.F. [MHz] | Reading of the measured VOR frequency  | MHz   |
| 4    | SQL           | Graphic display (bargraph) of the measured level, as well as the preset squelch threshold. The green line above the bargraph marks the valid range, which is indicated in the data sheet. Information contained in the datasheet has no or only limited validity in the range identified by the red or yellow bar. | dBm / dBµV  |
| 5    | LEVEL [dBm]   | Measured receive level (numerical / bargraph) in dBm / dBµV with the settable antenna correction factor (0.0) from the setup, if this level was selected as ≠0.0.  | dBm / dBµV<br> |

**3.10.1.2 Measured Values Section (4)**

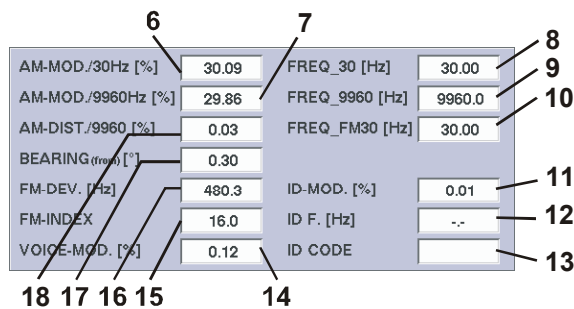







| Item | Display              | Function                                       | Indication |
|------|----------------------|--|------------|
| 6    | AM-MOD./ 30 Hz [%]   | AM-modulation factor, 30-Hz signal             | %          |
| 7    | AM-MOD./ 9960 Hz [%] | AM-Modulationsgrad, 9960-Hz-sub carrier signal | %          |
| 8    | FREQ_30 [Hz]         | measured 30-Hz frequency (AM modulates)        | Hz         |

| Item | Display              | Function   | Indication  |
|------|----------------------|--|-------------|
| 9    | FREQ_9960 [Hz]       | measured 9960-Hz frequency (AM modulates)  | Hz          |
| 10   | FREQ_FM30 [Hz]       | measured 30-Hz frequency (FM modulates)  | Hz          |
| 11   | ID-MOD.[%]           | Modulation factor of the Identifier  | %           |
| 12   | ID-F.[Hz]            | measured frequency of the Identifier   | Hz          |
| 13   | ID-CODE              | decoded identifier code  | e.g. "IKOW" |
| 14   | VOICE-MOD.[%]        | AM-Modulation factor of the voice signal (in the range 300 ... 3000 Hz, identifier notched)              | %           |
| 15   | FM-INDEX             | FM-Index   | Hz          |
| 16   | FM-DEV. [Hz]         | FM-Hub   | Hz          |
| 17   | BEARING (to/from)[°] | Phase between both 30-Hz signals<br>VOR direction (to = plane, from = station) is settable in the setup. | [°] Degree  |
| 18   | AM-DIST./ 9960 [%]   | AM-distortion at the 9960 Hz frequency   | %           |

\* Measurement accuracies are given in the Technical Data!

### 3.10.1.3 Softkey (2)

| Display   | Function   |
|---|--|
|  | Activates the edit function for the squelch threshold (SQL value is shown in the softkey)<br><br> <b>Setting of the squelch threshold to described in section 3.6!</b>  |
|  | Switch over of the RF-attenuation, set range is shown in the softkey: <ul style="list-style-type: none"> <li>- LOW NOISE (+10 dB),<br/>Indicating range: -120 ... -20 dBm</li> <li>- NORM (Normal, 0dB)<br/>Indicating range: -110 ... -10 dBm</li> <li>- LOW DIST (Low Distortion, -25dB)<br/>Indicating range: -100 ... 20 dBm</li> <li>- AUTO (the most favorable range will be selected automatically)<br/>Indicating range: -120 ... 20 dBm</li> </ul>  <b>The max. input level is +13 dBm. The Setting of the RF-Signal Adjustment to described in section 3.5!</b> |
|  | Activates the measurement time<br>Setting value: 10 ... 2000 ms (10 ms step width)<br><br> <b>Setting of the measurement time to described in section 3.7!</b>  |
|  | Switch over (1*) between Normal- and Large views, set mode is shown in the softkey: <ul style="list-style-type: none"> <li>- Normal (normal view)</li> <li>- Large (zoom view)</li> </ul>  |

**3.10.2 Setting the Receiving frequency in the VOR mode**
**VOR: 108 ... 118 MHz**

|    | Control | Operation  | Function   |
|----|---------|--|--|
| 1. |         | Press the "FREQ" (9) button.   | Behind the last digit the cursor appears.<br>  |
| 2. |         | Setting the corresponding frequency with rollkey / keyboard.                 | Enter the frequency, including the appropriate decimal places. If the frequency corresponds with a defined channel (ICAO frequency list, 3.10.3.1), then the channel number will be shown in the channel display window; otherwise dashes will be shown.<br> |
| 3. |         | Confirm with the correct dimension or Press the Enter button / rollkey push. | Acceptance of the new set frequency.<br>   |

**NOTES**







- 1) *On frequency input the complete frequency range (70 ... 350 MHz) can be entered independent from the mode. However, the data content is only given at mode specific frequency ranges:*

**VOR: 108 ... 118 MHz**

**With the "ESC" button any time a break off of the function is possible and the old value will be restored!**

- 2) *If the frequency setting will be performed with the rollkey or the cursor buttons, the corresponding target channels will be displayed according to the ICAO frequency list in the channel window.*
- 1) *The frequency step width (0.001 ... 10.000 MHz) is settable in the setup (F-Step) when using the rollkey or the cursor buttons.*

**3.10.3 Setting the Receiving channel in the VOR mode**

|    | Control  | Operation  | Function   |
|----|--|--|--|
| 1. |   | Press (2x) the "FREQ" (9) button.  | Switching over into the edit function for channel input (frequency assignment according to ICAO-frequency list, 3.10.3.1). The channel section is activated and behind the last digit the cursor appears.<br><br> |
| 2. |   | Use the rollkey / keyboard to set the respective channel number and use the up/down arrows to set X or Y | Only digits entry. (see also ILS-frequency / channel list). The frequency (ICAO frequency list, 3.10.3.1) associated with the channel will be displayed in the frequency field<br><br>                            |
| 3. |  | Press the Enter button / rollkey push.   | Acceptance of the new set channel no.<br><br>  |

**NOTES**

- 1) *On channel input via the tens keyboard the mode specific channel ranges must be observed:*

**VOR: 18X ... 56Y**

***When the channel ranges are exceeded or when they fall below, the digits in the frequency section will be displayed in red and they cannot be used!***

- 2) *With the "ESC" button any time a break off of the function is possible and the old value will be restored!*

- 1) *If the frequency setting will be performed with the rollkey or the cursor buttons, the corresponding frequencies will be displayed during setting!*

**3.10.3.1 VOR-Channel Frequency List**

| Channel (ICAO) | Frequency (MHz) |
|----------------|-----------------|
| 17X            | 108,00          |
| 17Y            | 108,05          |
| 19X            | 108,20          |
| 19Y            | 108,25          |
| 21X            | 108,40          |
| 21Y            | 108,45          |
| 23X            | 108,60          |
| 23Y            | 108,65          |
| 25X            | 108,80          |
| 25Y            | 108,85          |
| 27X            | 109,00          |
| 27Y            | 109,05          |
| 29X            | 109,20          |
| 29Y            | 109,25          |
| 31X            | 109,40          |
| 31Y            | 109,45          |
| 33X            | 109,60          |
| 33Y            | 109,65          |
| 35X            | 109,80          |
| 35Y            | 109,85          |
| 37X            | 110,00          |
| 37Y            | 110,05          |
| 39X            | 110,20          |
| 39Y            | 110,25          |
| 41X            | 110,40          |
| 41Y            | 110,45          |
| 43X            | 110,60          |
| 43Y            | 110,65          |
| 45X            | 110,80          |
| 45Y            | 110,85          |
| 47X            | 111,00          |
| 47Y            | 111,05          |
| 49X            | 111,20          |
| 49Y            | 111,25          |
| 51X            | 111,40          |
| 51Y            | 111,45          |
| 53X            | 111,60          |
| 53Y            | 111,65          |
| 55X            | 111,80          |
| 55Y            | 111,85          |
| 57X            | 112,00          |
| 57Y            | 112,05          |
| 58X            | 112,10          |
| 58Y            | 112,15          |
| 59X            | 112,20          |
| 59Y            | 112,25          |
| 70X            | 112,30          |
| 70Y            | 112,35          |
| 71X            | 112,40          |
| 71Y            | 112,45          |
| 72X            | 112,50          |
| 72Y            | 112,55          |
| 73X            | 112,60          |
| 73Y            | 112,65          |
| 74X            | 112,70          |
| 74Y            | 112,75          |
| 75X            | 112,80          |

| Channel (ICAO) | Frequency (MHz) |
|----------------|-----------------|
| 75Y            | 112,85          |
| 76X            | 112,90          |
| 76Y            | 112,95          |
| 77X            | 113,00          |
| 77Y            | 113,05          |
| 78X            | 113,10          |
| 78Y            | 113,15          |
| 79X            | 113,20          |
| 79Y            | 113,25          |
| 80X            | 113,30          |
| 80Y            | 113,35          |
| 81X            | 113,40          |
| 81Y            | 113,45          |
| 82X            | 113,50          |
| 82Y            | 113,55          |
| 83X            | 113,60          |
| 83Y            | 113,65          |
| 84X            | 113,70          |
| 84Y            | 113,75          |
| 85X            | 113,80          |
| 85Y            | 113,85          |
| 86X            | 113,90          |
| 86Y            | 113,95          |
| 87X            | 114,00          |
| 87Y            | 114,05          |
| 88X            | 114,10          |
| 88Y            | 114,15          |
| 89X            | 114,20          |
| 89Y            | 114,25          |
| 90X            | 114,30          |
| 90Y            | 114,35          |
| 91X            | 114,40          |
| 91Y            | 114,45          |
| 92X            | 114,50          |
| 92Y            | 114,55          |
| 93X            | 114,60          |
| 93Y            | 114,65          |
| 94X            | 114,70          |
| 94Y            | 114,75          |
| 95X            | 114,80          |
| 95Y            | 114,85          |
| 96X            | 114,90          |
| 96Y            | 114,95          |
| 97X            | 115,00          |
| 97Y            | 115,05          |
| 98X            | 115,10          |
| 98Y            | 115,15          |
| 99X            | 115,20          |
| 99Y            | 115,25          |
| 100X           | 115,30          |
| 100Y           | 115,35          |
| 101X           | 115,40          |
| 101Y           | 115,45          |
| 102X           | 115,50          |
| 102Y           | 115,55          |
| 103X           | 115,60          |
| 103Y           | 115,65          |

| Channel (ICAO) | Frequency (MHz) |
|----------------|-----------------|
| 104X           | 115,70          |
| 104Y           | 115,75          |
| 105X           | 115,80          |
| 105Y           | 115,85          |
| 106X           | 115,90          |
| 106Y           | 115,95          |
| 107X           | 116,00          |
| 107Y           | 116,05          |
| 108X           | 116,10          |
| 108Y           | 116,15          |
| 109X           | 116,20          |
| 109Y           | 116,25          |
| 110X           | 116,30          |
| 110Y           | 116,35          |
| 111X           | 116,40          |
| 111Y           | 116,45          |
| 112X           | 116,50          |
| 112Y           | 116,55          |
| 113X           | 116,60          |
| 113Y           | 116,65          |
| 114X           | 116,70          |
| 114Y           | 116,75          |
| 115X           | 116,80          |
| 115Y           | 116,85          |
| 116X           | 116,90          |
| 116Y           | 116,95          |
| 117X           | 117,00          |
| 117Y           | 117,05          |
| 118X           | 117,10          |
| 118Y           | 117,15          |
| 119X           | 117,20          |
| 119Y           | 117,25          |
| 120X           | 117,30          |
| 120Y           | 117,35          |
| 121X           | 117,40          |
| 121Y           | 117,45          |
| 122X           | 117,50          |
| 122Y           | 117,55          |
| 123X           | 117,60          |
| 123Y           | 117,65          |
| 124X           | 117,70          |
| 124Y           | 117,75          |
| 125X           | 117,80          |
| 125Y           | 117,85          |
| 126X           | 117,90          |
| 126Y           | 117,95          |



### 3.10.4 Switch over the Display view in the VOR mode

This function enables the display to be switched between normal- and large views. In the large view, the most important parameters of a mode are displayed extra large, enabling them to be read from a large distance. Channel number / frequency, as well as the use of the softkey are still available during the zoom function.

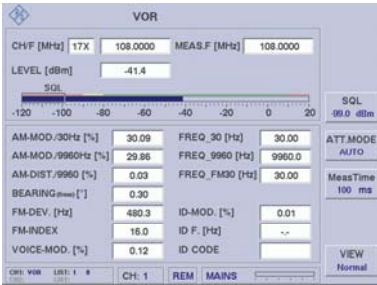
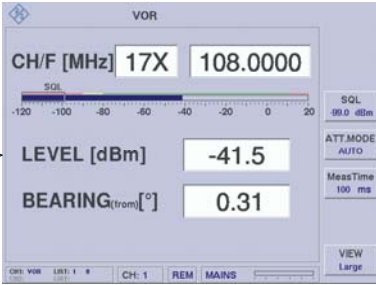
|    | Control   | Operation  | Function   |
|----|---|--|--|
| 1. |  | Press the softkey "VIEW".  | Switch over between Normal- and Large views, set mode is shown in the softkey<br>Selection:      Normal (normal view)<br>Large (zoom view) |
|    |   | <div style="display: flex; justify-content: space-around; align-items: center;"> <div style="text-align: center;">  <p>normal view</p> </div> <div style="font-size: 2em; color: blue;">→</div> <div style="text-align: center;">  <p>zoom view (large)</p> </div> </div> |  |

### 3.11 MARKER BEACON mode operation

Activates the MARKER BEACON mode

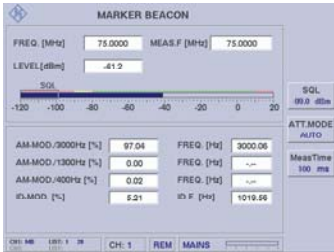
|    | Control   | Operation                   | Function  |
|----|---|-----------------------------|---|
| 1. |  | Taste "BEACON" (5) drücken. | The R&S® EVS 300 switches over into the MARKER BEACON mode. <div style="text-align: center; margin-top: 20px;">  </div> |

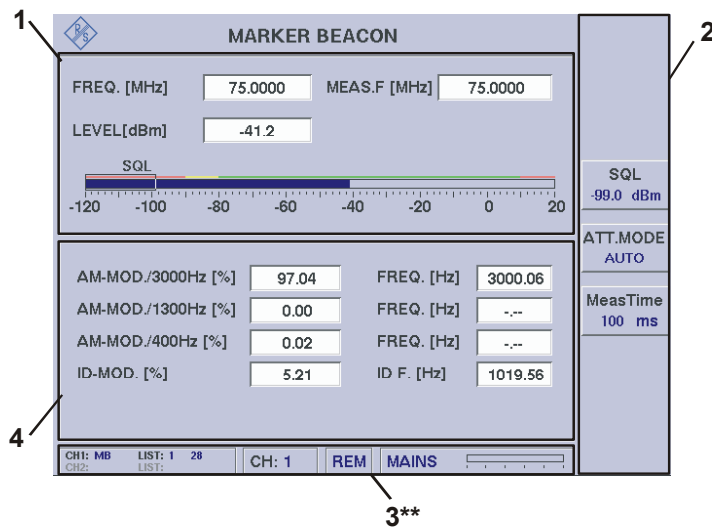
**3.11.1 Signal Parameters and Display in the MARKER BEACON mode**

3\*\* for general description of the status field see 3.2.1.1

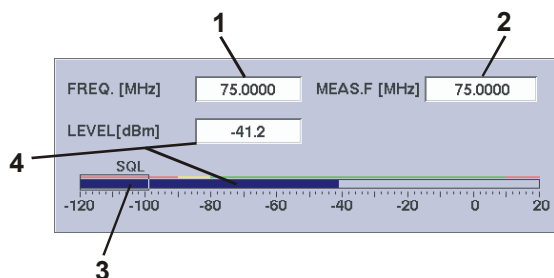
**3.11.1.1 RF Parameter Section (1)**

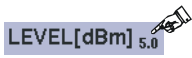

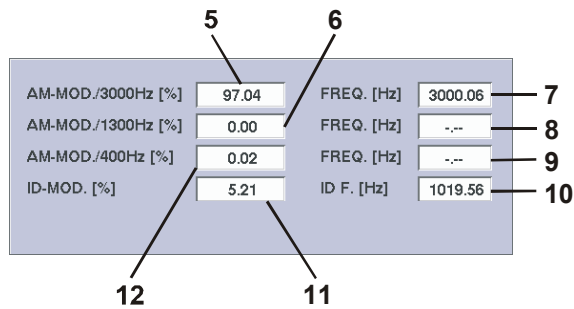



| Item | Display       | Function   | Indication  |
|------|---------------|--|---|
| 1    | FREQ. [MHz]   | Reading and setting of the receive frequency   | MHz   |
| 2    | MEAS.F. [MHz] | Reading of the measured beacon carrier frequency   | MHz   |
| 3    | SQL           | Graphic display (bargraph) of the measured level, as well as the preset squelch threshold. The green line above the bargraph marks the valid range, which is indicated in the data sheet. Information contained in the datasheet has no or only limited validity in the range identified by the red or yellow bar. | dBm / dBμV  |
| 4    | LEVEL [dBm]   | Measured receive level (numerical / bargraph) in dBm / dBμV with the settable antenna correction factor (0.0) from the setup, if this level was selected as ≠0.0.  | dBm / dBμV<br> |

**3.11.1.2 Measured Values Section (4)**

| Item | Display              | Function                                    |    |
|------|----------------------|---|----|
| 5    | AM-MOD./ 3000 Hz [%] | AM-modulation factor of the 3000-Hz markers | %  |
| 6    | AM-MOD./ 1300 Hz [%] | AM-modulation factor of the 1300-Hz markers | %  |
| 7    | FREQ. [Hz]           | measured 3000-Hz marker frequency           | Hz |
| 8    | FREQ. [Hz]           | measured 1300-Hz marker frequency           | Hz |
| 9    | FREQ. [Hz]           | measured 400-Hz marker frequency            | Hz |
| 10   | ID F. [Hz]           | measured identifier frequency               | Hz |
| 11   | ID-MOD. [%]          | AM-modulation factor of the identifier      | %  |
| 12   | AM-MOD./ 400 Hz [%]  | AM- modulation factor of the 400-Hz marker  | %  |

\* Measurement accuracies are given in the Technical Data!

**3.11.1.3 Softkeys (3)**





| Display   | Function   |
|---|--|
|  | Activates the edit function for the squelch threshold (SQL value is shown in the softkey)<br> <b>Setting of the squelch threshold to described in section 3.6!</b>  |
|  | Switch over of the RF-attenuation, set range is shown in the softkey: <ul style="list-style-type: none"> <li>- LOW NOISE (+10 dB),<br/>Indicating range: -120 ... -20 dBm</li> <li>- NORM (Normal, 0dB)<br/>Indicating range: -110 ... -10 dBm</li> <li>- LOW DIST (Low Distortion, -25dB)<br/>Indicating range: -100 ... 20 dBm</li> <li>- AUTO (the most favorable range will be selected automatically)<br/>Indicating range: -120 ... 20 dBm</li> </ul>  <b>The max. input level is +13 dBm. The Setting of the RF-Signal Adjustment to described in section 3.5!</b> |
|  | Activates the measurement time<br>Setting value: 10 ... 2000 ms (10 ms step width)<br> <b>Setting of the measurement time to described in section 3.7!</b>  |



3.11.2 Setting the Receiving frequency in the MARKER BEACON mode

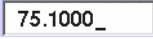

MARKER BEACON: 74,7 ... 75,3 MHz

|    | Control   | Operation  | Function   |
|----|---|--|--|
| 1. |  | Press the "FREQ" (9) button.   | Behind the last digit the cursor appears.<br>                             |
| 2. |  | Setting the corresponding frequency with rollkey / keyboard.                 | The frequency should be entered with the corresponding decimal place.<br> |
| 3. |  | Confirm with the correct dimension or Press the Enter button / rollkey push. | Acceptance of the new set frequency.<br>                                  |

**Notes**



- 1) *On frequency input the complete frequency range (70 ... 350 MHz) can be entered independent from the mode. However, the data content is only given at mode specific frequency ranges:*

**MARKER BEACON: 74.7 ... 75.3 MHz**

- 2) *With the "ESC" button any time a break off of the function is possible and the old value will be restored!*
- 3) *The frequency step width (0.001 ... 10.000 MHz) is settable in the setup (F-Step) when using the rollkey or the cursor buttons.*

### 3.12 F SCAN and FFT mode (Options) operation

 **F SCAN mode and FFT mode are software options, which can be installed in the R&S® EVS 300 independently from each other.**

**In the following text, the operation of these modes will be discussed separately; however, some operating features are identical.**

In F SCAN mode, the settings for the receiving frequency and Marker function are activated via the device buttons "FREQ" (9) and "MARKER" (11). Depending on the selected function, the respective softkeys will be shown in the F SCAN display. In the modes F SCAN / FFT, the following settings will be stored individually for each mode:

- Frequency settings,
- Marker settings,
- Reference level,
- RF mode,
- Trace settings,
- Display settings

#### Activates the F SCAN mode

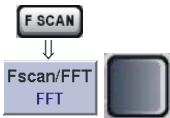
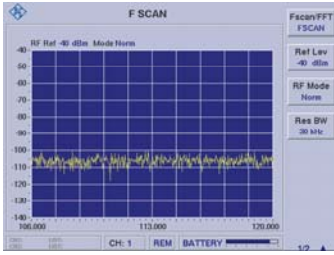
|    | Control   | Operation   | Function   |
|----|---|---|--|
| 1. |  | Press the "F SCAN" (8) button and change with softkey "F SCAN / FFT" in the F SCAN mode if necessary. | The R&S® EVS 300 switches over into the F SCAN mode.<br> |

 **If both options are installed, the system switches to that mode, which was active last, either F SCAN- or FFT mode.**



3.12.1 Signal Parameters and Display in the F SCAN mode (Option EVS-K1)

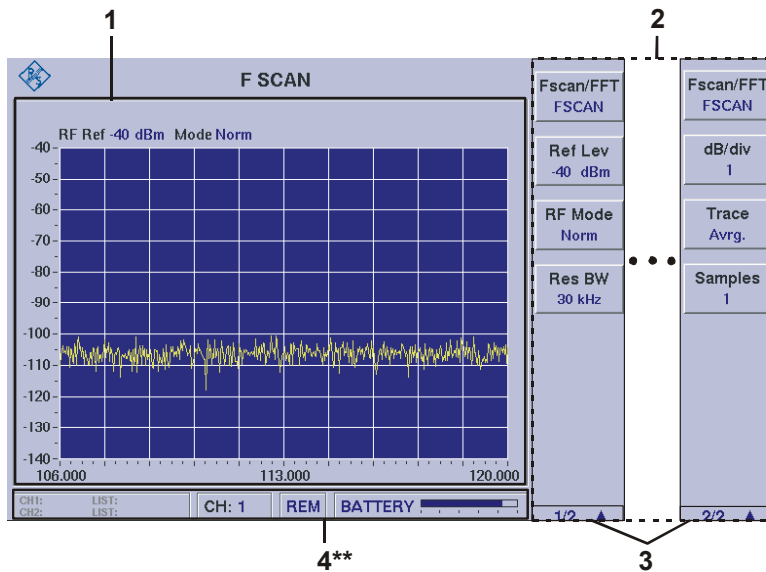

4\*\* for general description of the status field see 3.2.1.1



Due to the multitude of settings offered, two softkey windows are available. The currently displayed softkey window will be identified with the 1/2 e.g. 2/2 ▲ -symbol (3). Use the "▲" -button to switch back and forth between the softkey windows.



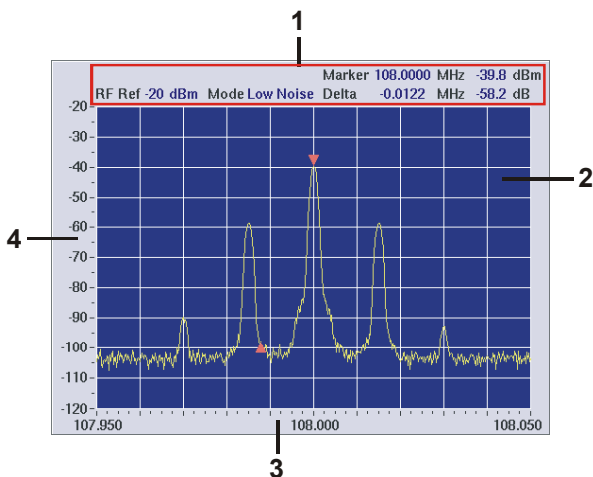

3.12.1.1 Spectrum-Display F SCAN (1)



| Item | Display              | Function  | Indication |
|------|----------------------|---|------------|
| 1    | Parameter indication | Indication and setting of the following parameter:<br>RF REF:<br>Indication of the reference level in dBm / dBµV. |            |

| Item | Display            | Function  | Indication         |
|------|--------------------|---|--------------------|
|      |                    | <p>Mode:<br/>Indication of the ATT mode, set with the "RF Mode" softkey.</p> <p>Marker:<br/>Indication and setting of the Marker frequency (MHz) and indication of the measured level (dBm / dBμV).</p> <p>Delta:<br/>Indication and setting of the Delta Marker frequency (MHz) and indication of the measured level difference in dB.</p> |                    |
| 2    | indication         | <p>Graphic display (bargraph) of the frequency spectrum, indication of level vs. frequency.</p> <p>Y-axis= level<br/>X-axis= frequency</p>  | frequency spectrum |
| 3    | Frequency (X-axis) | Frequency scale   | MHz                |
| 4    | Level (Y-axis)     | Level scale   | dBm / dBμV         |

### 3.12.1.2 Softkeys (2)

| Display   | Function  |
|---|---|
| <b>window 1</b>   |   |
|  | <p>Switching of the analysis mode, F SCAN or FFT, if both options are installed.</p> <p>F SCAN = spectrum analysis of the receiver signal<br/>           FFT = analysis of the demodulated baseband signal or one of the externally fed AF signals (BASEBAND IN)<br/>           (FFT = Fast Fourier Transform)</p>  |
|  | <p>Setting of the reference level, set level (dBm / dBμV settable in the setup) is shown in the softkey and the display.</p> <p>Setting value: +20 ... -100 dBm</p>   |
|  | <p>Switch over of the RF-attenuation, set range is shown in the softkey:</p> <ul style="list-style-type: none"> <li>- LOW NOISE (+10 dB),<br/>Indicating range: -120 ... -20 dBm</li> <li>- NORM (Normal, 0dB)<br/>Indicating range: -110 ... -10 dBm</li> <li>- LOW DIST (Low Distortion, -25dB)<br/>Indicating range: -100 ... 20 dBm</li> <li>- Coupled, coupling of the reference level with an automatic adjustment of the RF input attenuation</li> </ul> <p> <b>The max. input level is +13 dBm. The Setting of the RF-Signal Adjustment to described in section 3.5!</b></p> |



| Display         | Function   |
|-----------------|--|
|                 | Switch over of the bandwidth<br>Selection: 30 kHz, 10 kHz, 3 kHz, 1 kHz  |
| <b>window 2</b> |  |
|                 | Setting of the resolution (scaling of the Y axis), set level is shown in the softkey:<br>Selection: 10 dB, 5 dB, 2 dB, 1 dB  |
|                 | Switch over of the trace function, set function is shown in the softkey:<br>Selection: Clr / Wr. (Clear / Write)<br>Avg. (Average)<br>Max Hold<br>View                                     |
|                 | Setting the number of samples, for the average, set number of samples is shown in the softkey.<br>Setting range: 1 ... 100<br><i>Can only be adjusted in the Trace function "Average".</i> |

### 3.12.2 Frequency setting at F SCAN mode

In F SCAN mode all receiving frequency settings are activated via the device button "FREQ" (9). Depending on the selected function, the softkeys will be shown in the F SCAN display. At this point, the start, stop, center, and span frequency can be entered.

Example: Flow of a frequency setting

|    | Control | Operation                    | Function  |
|----|---------|------------------------------|---|
| 1. |         | Press the "FREQ" (9) button. | The softkeys for the frequency setting in F SCAN mode are shown.<br>Softkey: Start F (entering start frequency),<br>Softkey: Stop F (entering stop frequency),<br>Softkey: Center F (entering center freq.),<br>Softkey: Span F (entering span frequency) |

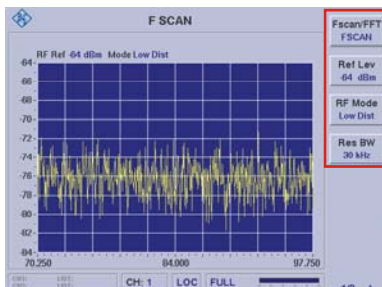



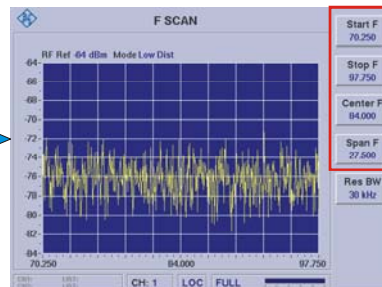

Normal view F SCAN mode



Frequency setting view







**3.12.2.1 Softkeys (2) of the Frequency setting**



| Display   | Function   |
|---|--|
|  | Activates the edit function for the start frequency, set frequency is shown in the softkey.  |
|  | Activates the edit function for the stop frequency, set frequency is shown in the softkey.   |
|  | Activates the edit function for the center frequency, set frequency is shown in the softkey. |
|  | Activates the edit function for the span frequency, set frequency is shown in the softkey.   |

**3.12.3 Flow of a Frequency setting in F SCAN mode**

In the following text, the flow for the setting of the start frequency will be described. These steps are also representative for the setting **Stop, Center, and Span frequency**.

|  | Control   | Operation   | Function  |
|--|---|---|---|
| 1.   |  | Press the softkey "START F".                          | Activation of the edit function for changing the start frequency.<br>                      |
| 2.   |  | Turn the rollkey until the required frequency is set. | Setting the new start frequency.<br>- = Frequency decreases<br>+ = Frequency increases<br> |
| <p>Features: When setting the frequencies, the analogously linked frequencies will be automatically adjusted. The respective changes will be displayed simultaneously in the associated softkeys. The following frequency dependencies are set:</p> <p>Start frequency setting: Center and Span frequency are adapted,<br/>           Stop frequency setting: Center and Span frequency are adapted,<br/>           Center frequency setting: Start and Stop frequency are adapted,<br/>           Span frequency setting: Start and Stop frequency are adapted.</p> |   |   |   |
| 3.   |  | Press the Enter button / rollkey push.                | Acceptance of the actually set new start frequency.   |

**3.12.4 Setting the IF bandwidth**

|    | Control   | Operation  | Function  |
|----|---|--|---|
| 1. |  | Hold the softkey "RES BW" depressed until the IF bandwidth is set. | <p>The IF bandwidth changes and the set value is displayed in the softkey.</p>  <p>Selection: 30 kHz, 10 kHz, 3 kHz, 1 kHz</p> |

When setting a lower IF bandwidth, the resolution of the frequency spectrum will be increased. In addition, the hissing sound will be reduced and subsequently the input sensitivity will be increased.

Depending on the preset span frequency range, the following settable IF bandwidths are permitted:





|                          |                                      |
|--------------------------|--------------------------------------|
| Span frequency: <2 MHz   | RES BW: 30 kHz, 10 kHz, 3 kHz, 1 kHz |
| Span frequency: >2 MHz   | RES BW: 30 kHz, 10 kHz, 3 kHz        |
| Span frequency: >20 MHz  | RES BW: 30 kHz, 10 kHz               |
| Span frequency: >100 MHz | RES BW: 30 kHz                       |

**3.12.5 Setting the Reference level**



The reference level indicates the max. permissible level value of the input signal, which can be displayed undistorted. Higher signal levels cause overmodulation of the receiver; should this happen, a warning will be displayed.



**The maximal levels of the individual RF modes must be adhered to. They must not be exceeded, even if the reference level (REF LEV) is set higher!**

|    | Control   | Operation   | Function  |
|----|---|---|---|
| 1. |  | Press the softkey "REF LEV".                      | <p>Activation of the edit function for reference level, set value is shown in the softkey.</p>           |
| 2. |  | Turn the rollkey until the required level is set. | <p>Setting of the reference level, set level Pegel (dBm / dBμV settable in the setup) is shown in the softkey and the display.</p> <p>Setting range: -100 ... +20 dBm,<br/>7 ... 127 dBμV</p> |
| 3. |  | Press the Enter button / rollkey push.            | Acceptance of the actually set new reference level.   |

**3.12.6 Setting the RF mode**

|  | Control   | Operation  | Function                        |
|--|---|--|---------------------------------|
| 1.   |  | Hold the softkey "RF Mode" depressed until the RF mode is set. | Switch over the RF attenuation. |
| Switch over of the RF-attenuation, set range is shown in the softkey: <ul style="list-style-type: none"> <li>- LOW NOISE (+10 dB),<br/>Indicating range: -120 ... -20 dBm</li> <li>- NORM (Normal, 0dB)<br/>Indicating range: -110 ... -10 dBm</li> <li>- LOW DIST (Low Distortion, -25dB)<br/>Indicating range: -100 ... 20 dBm</li> <li>- Coupled, coupling of the reference level with an automatic adjustment of the RF input attenuation</li> </ul> |   |  |                                 |
|  <b>The max. input level is +13 dBm. The Setting of the RF-Signal Adjustment to described in section 3.5!</b>   |   |  |                                 |



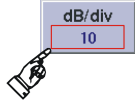

**3.12.7 Setting the Resolution (level scale)**

To analyze very small spectral shares of a signal the resolution of the Y axis can setting gradually 10 ... 1 dB.

|    | Control   | Operation                     | Function  |
|----|---|-------------------------------|---|
| 1. |  | Press the softkey "dB / div". | Setting the resolution (level scale), set value is shown in the softkey. The respective setting becomes effective immediately.<br><br><br><br>Selection: 10 dB, 5 dB, 2 dB, 1 dB |

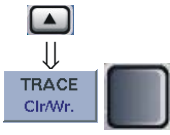

3.12.8 Setting Trace function

|    | Control   | Operation   | Function   |
|----|---|---|--|
| 1. |    | Switch to the second menu window and press the softkey "Trace". | <p>Setting at Trace function, set function is shown in the softkey.</p>  <p>Selection: Clr / Wr. (Clear / Write), Average, Max Hold, View</p> <p>Explanation of the "Trace" functions:</p> <p><b>Clear / Write:</b> In the Clear / Write function, the display of the measured spectrum is continuously updated, i.e. the Trace memory is rewritten with each sweep.</p> <p><b>Average:</b> In the Average function, the mean value of several sweeps will be calculated and displayed. This is a floating message, i.e. after each sweep, the display is updated, showing the mean value of a number of previous sweeps. The number of these sweeps can be set via the "Samples" softkey. When starting the "Average" function, or when changing the number of samples, all available sweeps are determined first, until a sufficient number of test samples are available in the memory and a floating message can be used.</p> <p><b>Max Hold:</b> When using the "Max Hold" function, the peak values of the captured spectrum can be stored automatically. With each sweep, the display is being updated. However, the displayed curve will only be overwritten in those areas, where the currently captured data is larger than the previously displayed value in the same location.</p> <p><b>View:</b> With the "View" function, the current spectrum can be "frozen"</p> |
| 2. |  | Press the softkey "Samples".                                    | <p>Setting the number of samples to the Trace "Average" function, set number of samples is shown in the softkey.</p>  <p>Setting range: 1 ... 100 (samples)</p> <p> <b>The "Samples" softkey is only activated during the "Average" function!</b></p>  |

### 3.12.9 Calling up the Marker function

The Marker functions are applicable for both, the F SCAN and the FFT function. The activation of the Marker function is identical for both analysis functions.

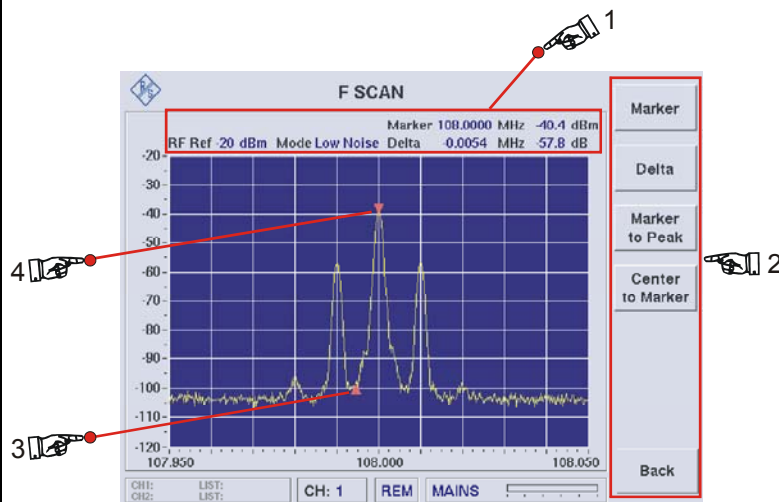

|    | Control   | Operation                       | Function   |
|----|---|---------------------------------|--|
| 1. |  | Press the "Marker" (11) button. | The softkeys for the Marker settings in F SCAN / FFT mode will be shown, the parameter display (1) will be expanded to show the Marker's frequency and level as well as the Delta Marker |







Parameteranzeige (1): RF REF, display of the reference level in dBm / dB $\mu$ V  
 Mode, displays the ATT mode, which was set with the softkey "RF Mode"  
 Marker, display and setting of the Marker frequency (MHz) and the display of the measured level (dBm / dB $\mu$ V)  
 Delta, display and setting of the Delta Marker frequency (MHz) and the display of the measured level difference in dB.

Softkeys (2): Marker, Delta Marker, Marker to Peak, Center to Marker  
 Delta Marker (3): Example, signed Delta Marker  
 Marker (4): Example, signed Marker

#### 3.12.9.1 Softkeys (2) of the Marker function

| Display   | Function   |
|---|--|
|  | Activates the Marker function and the frequency setting of the Marker, setting and display in the parameter display.             |
|  | Activates the Delta Marker function and the frequency setting of the Delta Marker, setting and display in the parameter display. |
|  | Activates the Peak Marker function, on pressing the button, the Marker will be set on the highest signal within the spectrum     |









| Display   | Function  |
|---|---|
|   |  <b>The Peak Marker function can only be switched on while the Marker is activated!</b>  |
|  | Activates the Center Marker function, on pressing the button, the current Marker frequency will be set to the new Center frequency.<br><br> <b>The Center Marker function can only be switched on while the Marker is activated!</b> |
|  | Change to the F SCAN Softkey window 1/2 switched on before.   |





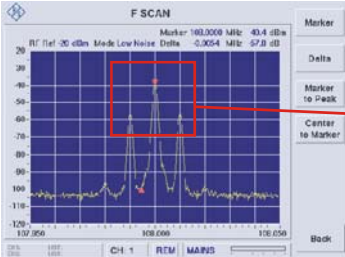
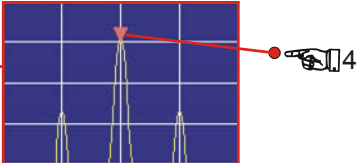

### 3.12.9.2 Explanation of the different Marker functions

The following text describes a sample flow of the different Marker functions, these are:

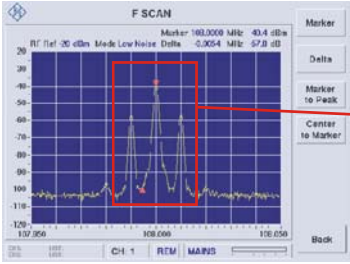
- Marker function,
- Delta Marker function,
- Peak Marker function,
- Center Marker function

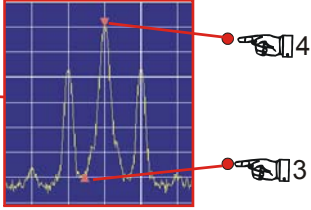
 **The Center Marker function is only available in the F SCAN mode!**

| Control  | Operation                   | Function   |
|--|-----------------------------|--|
| <b>Marker function:</b>  |                             |  |
| 1.   | Press the softkey "Marker". | The Marker (4) will be shown, i.e. the automatic search and identification of the spectrum's max. value will be initiated (only if the Marker was not activated previously). In addition, the rollkey can be used to set the Marker's frequency. Pressing the softkey again, will deactivate the Marker.<br><br> |
|   |                             |    |
| <b>Delta Marker function:</b>  |                             |  |
| 2.   | Press the softkey "Delta".  | Delta Marker (3) will be shown as Marker (4), i.e. if the marker has not been activated prior, it will be automatically set to the highest signal. The display will show the level and the frequency difference with respect to  |

|                                | Control   | Operation   | Function   |
|--------------------------------|---|---|--|
|                                |   |    | <p>the reference marker.</p>     |
| <b>Peak Marker function:</b>   |   |   |  |
| 3.                             |    | <p>Press the softkey "Marker to Peak".</p>  <p><b><i>The Peak Marker function can only be switched on while the Marker is activated!</i></b></p>   | <p>After pressing the button, the Marker (4) will be set on the highest signal within the spectrum. The level and frequency displays will be automatically updated. If the Delta Marker (3) is activated, the level and frequency difference with respect to the reference Marker will also be updated in its display.</p> |
| <b>Center Marker function:</b> |   |   |  |
| 4.                             |  | <p>Press the softkey "Center to Marker".</p>  <p><b><i>The Center Marker function can only be switched on while the Marker is activated. This function is only available in the F SCAN mode!</i></b></p> | <p>After pressing the button, the current Marker frequency will be set to the new Center frequency. By doing so, any Delta Marker which is switched on, will be dragged along accordingly. The frequency display will be updated according to the preset Span frequency.</p>   |



### 3.13 FFT mode (Option) operation



*F SCAN mode and FFT mode are software options, which can be installed in the R&S® EVS 300 independently from each other.*

While in FFT mode, the settings for the frequency and for the Marker functions are activated via the device buttons "FREQ" (9) and "MARKER" (11). Depending on the selected function, the respective softkeys will be shown in the F SCAN display. In the modes F SCAN / FFT, the following settings will be stored for each mode:

- Frequency settings,
- Marker settings,
- Reference level,
- RF mode,
- Trace settings,
- Display settings



*The operation of the following settings and functions is identical with those of the F SCAN mode. For further information, please refer to the description of the F SCAN mode.*

- *Setting the reference level (3.12.5)*
- *Setting the RF mode (3.12.6)*
- *Setting the indication resolution (3.12.7)*
- *Trace functions (3.12.8)*
- *Marker functions (3.12.9)*

#### Activates the FFT mode

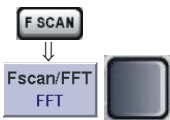
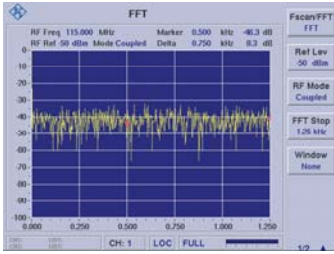
|    | Control   | Operation   | Function  |
|----|---|---|---|
| 1. |  | Press the "F SCAN" (8) button and change with softkey "F SCAN / FFT" in the F SCAN mode if necessary. | <p>The R&amp;S® EVS 300 switches over into the FFT mode.</p>  |



*If both options are installed, the system switches to that mode, which was active last, either F SCAN- or FFT mode.*



3.13.1 Signal Parameters and Display in the FFT mode (Option EVS-K4)

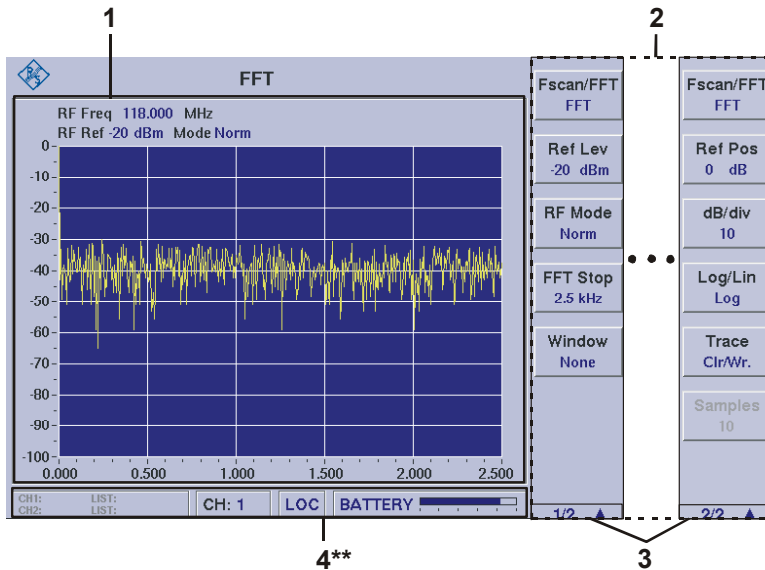

4\*\* for general description of the status field see 3.2.1.1



Due to the multitude of settings offered, two softkey windows are available. The currently displayed softkey window will be identified with the 1/2 e.g. 2/2 ▲ -symbol (3). Use the "▲" -button to switch back and forth between the softkey windows.



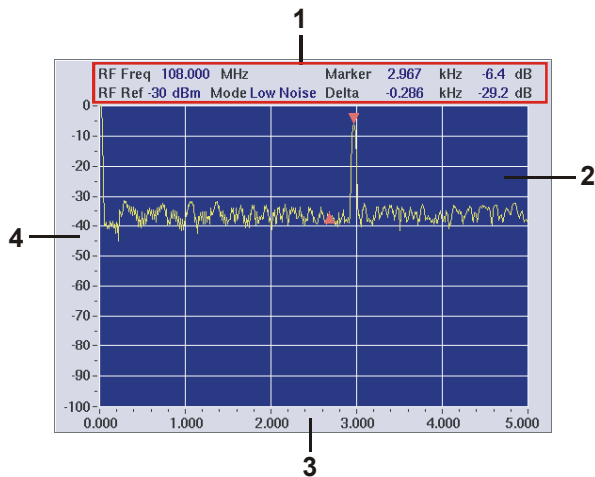

3.13.1.1 Spectrum-Display FFT (1)







| Item | Display              | Function   | Indication |
|------|----------------------|--|------------|
| 1    | Parameter indication | Indication and setting of the following parameter:<br>RF Freq:<br>Indication and setting of the RF receive frequency in MHz. |            |



| Item | Display            | Function   | Indication         |
|------|--------------------|--|--------------------|
|      |                    | <b>RF REF:</b><br>Indication of the reference level in dBm / dB $\mu$ V.<br><br><b>Mode:</b><br>Indication of the ATT mode, set with the "RF Mode" softkey.<br><b>Marker:</b><br>Indication and setting of the Marker frequency (MHz) and indication of the measured level (dBm / dB $\mu$ V).<br><br><b>Delta:</b><br>Indication and setting of the Delta Marker frequency (MHz) and indication of the measured level difference in dB. |                    |
| 2    | indication         | Graphic display (bargraph) of the frequency spectrum, indication of level vs. frequency.<br><br>Y-axis= level<br>X-axis= frequency   | frequency spectrum |
| 3    | Frequency (X-axis) | Frequency scale  | kHz                |
| 4    | Level (Y-axis)     | Level scale  | dB                 |

**3.13.1.2 Softkeys (2)**

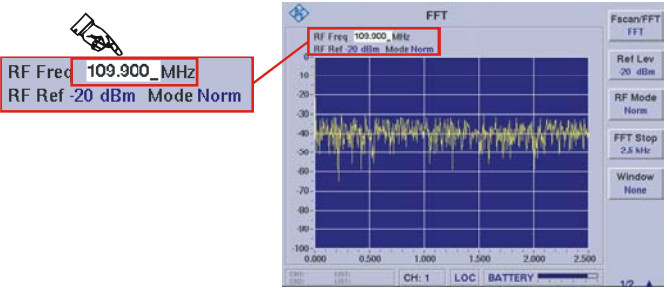

| Display   | Function   |
|---|--|
| <b>window 1</b>   |  |
|  | Setting of the reference level, set level (dBm / dB $\mu$ V settable in the setup) is shown in the softkey and the display.<br>Setting value: +20 ... -100 dBm   |
|  | Switch over of the RF-attenuation, set range is shown in the softkey: <ul style="list-style-type: none"> <li>- LOW NOISE (+10 dB),<br/>Indicating range: -120 ... -20 dBm</li> <li>- NORM (Normal, 0dB)<br/>Indicating range: -110 ... -10 dBm</li> <li>- LOW DIST (Low Distortion, -25dB)<br/>Indicating range: -100 ... 20 dBm</li> <li>- Coupled, coupling of the reference level with an automatic adjustment of the RF input attenuation</li> </ul><br> <b>The max. input level is +13 dBm. The Setting of the RF-Signal Adjustment to described in section 3.5!</b> |
|  | Activates the edit function for the FFT stop frequency, set frequency is shown in the softkey.   |
|  | Setting of the FFT window function, set function is shown in the softkey:<br>The following functions can be select: None, Hann, Flat Top   |

| Display   | Function   |
|---|--|
| <b>window 2</b>   |  |
|  | Setting the reference position (upper value of the Y axis) will shift the display in the direction of the Y axis by the entered value:<br>Setting range: 10 ... -90 dB                     |
|  | Setting of the resolution (scaling of the Y axis), set level is shown in the softkey:<br>Selection: 10 dB, 5 dB, 2 dB, 1 dB  |
|  | Switching between linear and logarithmic frequency axis; the set function will be displayed in the softkey.  |
|  | Switch over of the trace function, set function is shown in the softkey:<br>Selection: Clr / Wr. (Clear / Write)<br>Avg. (Average)<br>Max Hold<br>View                                     |
|  | Setting the number of samples, for the average, set number of samples is shown in the softkey.<br>Setting range: 1 ... 100<br><i>Can only be adjusted in the Trace function "Average".</i> |



### 3.13.2 Setting the Receiving frequency

|    | Control  | Operation  | Function  |
|----|--|--|---|
| 1. |   | Press the "FREQ" (9) button.   | In the frequency field, behind the last digit the cursor appears.     |
|    |  <p style="text-align: center;">Frequency settings view</p> |  |   |
| 2. |   | Setting the corresponding frequency with rollkey / keyboard.                 | The frequency should be entered with the corresponding decimal place. |
| 3. |   | Confirm with the correct dimension or Press the Enter button / rollkey push. | Acceptance of the new set frequency.                                  |

**3.13.3 Setting the FFT stop frequency**

|    | Control   | Operation   | Function  |
|----|---|---|---|
| 1. |  | Hold the softkey "FFT Stop" depressed until the frequency is set. | Switch over of the FFT stop frequency, set value is shown in the softkey. The analysis area (resolution of the X axis) is setting here.<br><br><br><br>Selection: 20 kHz, 10 kHz, 5 kHz, 2,5 kHz, 1,25 kHz, 0,625 kHz, |

**3.13.4 Setting a Window function**

|    | Control   | Operation  | Function  |
|----|---|--|---|
| 1. |  | Hold the softkey "Window" depressed until the function is set. | Switch over of the window function, set method is shown in the softkey.<br><br><br><br>Selection: None, Hann, Flat-Top |

In order to minimize the Leakage Effect, the signal allocated for the analysis, must be "windowed" after scanning, i.e. the time during which the spectrum is viewed, must be limited. By selecting this temporarily limited function, the quality of the display, the amplitude and the resolution of the frequency is affected. The R&S® EVS 300 offers two types of "windows", windowing per Hann or Flat Top.

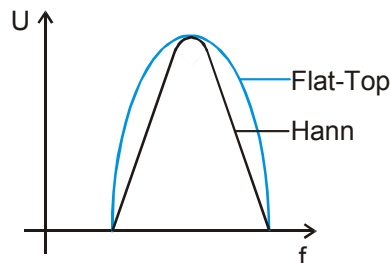

Hann method: This type of windowing is suitable for measurements requiring high frequency accuracy and resolution.

Flat-Top method: This windowing function is suitable for precise amplitude measurements with low frequency resolution.





Example: Flat-Top and Hann windowing

**3.13.5 Switching between Logarithmic or Linear display (Log / Lin)**

|    | Control   | Operation                      | Function   |
|----|---|--------------------------------|--|
| 1. |  | Press the softkey "Log / Lin". | Switching between a logarithmic or a linear display. In the logarithmic display, the setting for the resolution of the Y axis can be selected as "dB per unit" and in the linear display, the resolution can be selected as "% per unit". The selected function will be shown in the softkey.<br><br><br><br>Selection: Log / Lin |

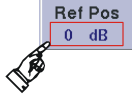
**3.13.6 Setting the Reference position**

|    | Control   | Operation   | Function  |
|----|---|---|---|
| 1. |  | Press the softkey "Ref Pos".                      | The editing function for changing the reference position of the Y axis will be active.<br><br>   |
| 2. |  | Turn the rollkey until the required level is set. | Causes a shift of the display in the amount of the entered value and in direction of the Y axis. When using the "Log / Lin" softkey, either the logarithmic or the linear display may be selected. If selecting the logarithmic display, the measuring unit "dB" will be displayed in the "Ref Pos" softkey; if selecting the linear display, the measuring unit "%" will be used.<br><br>Setting range Log: 10 ... -90 dB<br>Setting range Lin: 10 ... 110 % |
| 3. |  | Press the Enter button / rollkey push.            | Acceptance of the new set reference position.   |



### 3.14 Data Logger operation

The Data Logger records and manages series of measurements or individual data. For each mode up to 999 lists with max. 1.000.000 data lines each may be recorded. The dataset lists are stored on the internal Compact-Flash card of the R&S® EVS 300. For further processing, the dataset lists may be transferred in CSV format to a USB-memory stick.

In the ILS mode, the user interface of the Data Logger consists of 5 menu windows, while the VOR and MARKER BEACON modes contain 2 menu windows, which can all be accessed via softkeys or the shift button "⇧" (35). All menu windows refer to the currently active mode, e.g.: "ILS". The following menu windows of the Data Logger may be called up

1. menu window "Dataset list" (top window Data Logger)
2. menu window "Parameter settings"
3. menu window "ILS-Graph" (only the ils mode attainable)
4. menu window "ILS-Graph-Trace"
5. menu window "ILS-Graph-Marker"

Graphic overview, showing the assignment of the menu windows within the Data Logger mode

1. Menüfenster "Datensatzliste"

2. Menüfenster "Parametereinstellungen"

3. Menüfenster "ILS-Graph"

4. Menüfenster "ILS-Graph-Trace"

5. Menüfenster "ILS-Graph-Marker"

..... nur im ILS-Mode erreichbar

**Activates the Data Logger function**

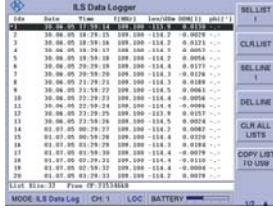
|    | Control   | Operation                    | Function   |
|----|---|------------------------------|--|
| 1. |  | Press the "MEM" (41) button. | The R&S® EVS 300 switches over into the Data Logger function.<br><br> |

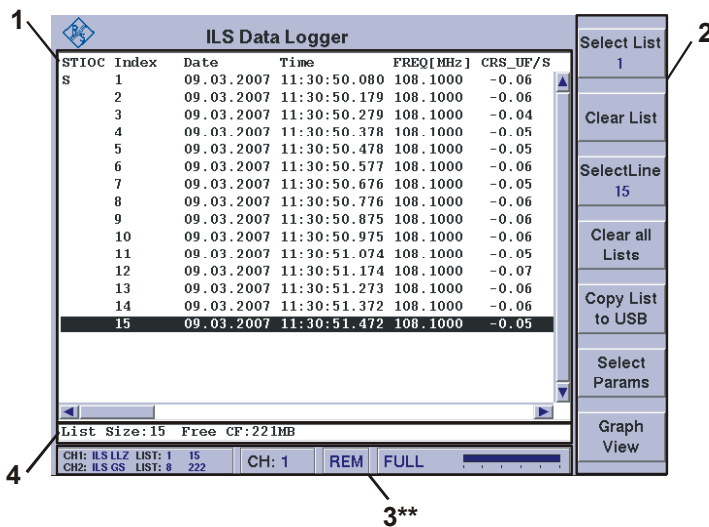

**In order to access a dataset of a particular mode, e.g.: ILS, the ILS mode must also be turned on. Each device mode may consist of up to 999 lists with max. 1.000.000 data lines (datasets) each.**

**3.14.1 Signal Parameters and Display in the menu window "Dataset lists"**

**3.14.1.1 Dataset list (1)**

All available data of the applicable mode will be entered into the dataset list, i.e for the following modi different data set listings will be compiled:

- ILS mode,
- VOR mode,
- MARKER BEACON mode.

While in the ILS mode, it further depends on the measuring modes (MEAS.MODE: Single, CRS+CLR etc.), as well as the VIEW modes (Normal, Distortion), which data will be captured and entered into the dataset list.



Each mode may consist of up to 999 lists (1.000.000 data lines / list) each. To each mode, individual parameters can be assigned, which should be shown in the dataset list. Use the menu window "Parameter settings" to select the applicable parameter-specific modes.









Structure of the dataset list:

| STIOC | Index | Date       | Time         | FREQ[MHz] | CRS_UF/S |
|-------|-------|------------|--------------|-----------|----------|
| S     | 1     | 09.03.2007 | 11:30:50.080 | 108.1000  | -0.06    |

| Item | Function   |
|------|--|
| 1    | <p>Column "STIOC" identifies the datasets within the list. Each letter within the column receives an identification, which in turn can also be found in the list below the respective letter. The following identification letters may be displayed:</p> <p><b>Start:</b> "S" will always be set, if a single dataset is accepted with the button "SAVE, (42)", or if the button "START, (10)" is used to initiate a series of measurements.</p> <p><b>Trigger:</b> "T" marks a dataset, which was prompted by an external trigger mechanism.</p> <p><b>Invalid:</b> "I" indicates the recording of a dataset at a time, when the measurement level was either not permitted or too low (within the red range of the bargraph).</p> <p><b>Overload:</b> "O" indicates the recording of a dataset at a time, when the RF input signal was too high.</p> <p><b>Correction:</b> "C" indicates that the dataset was recorded at a time, when the measurement included the RF input correction factor</p> |
| 2    | <p>In the "Index" column each dataset which is entered, receives an index number. This serves two purposes, firstly, each dataset entered is recorded chronologically and secondly, specific data can be selected and displayed graphically.</p>   |
| 3    | <p>Data display: the order and the selection of the parameters of a dataset can be set individually in the menu window "Parameter settings".</p>   |



**3.14.1.2 Softkeys (2) of the menu window "Dataset list"**

| Display   | Function  |
|---|---|
|    | Selection of a data set list (1 ... 999, listno. is shown in the softkey)<br><br> <b>Each unit mode can deal with max. 999 listings!</b>                 |
|    | Deletes the current list  |
|    | Marks a line of the current list (line no. is shown in the softkey) with scroll function<br><br> <b>A list can have about max. 1.000.000 data lines!</b> |
|    | Deleting all lists of the current mode  |
|    | To copy the current list onto an USB-memory-stick   |
|   | Switching to the parameter window. In this window, the parameter of the active mode (e.g.: ILS) can be selected, which will be accepted into the dataset list.  |
|  | Switching to the graphic display of DDM values. This function is only available in ILS mode. In the modes VOR and MARKER BEACON, the softkey is hidden.   |

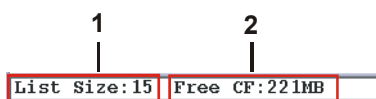
**3.14.1.3 Memory Status Information (4)**

| Item | Display   | Function  | Indication |
|------|-----------|---|------------|
| 1    | List Size | Number of measured lines within the current dataset list (one line equals one measurement). |            |
| 2    | FREE CF   | Display of available memory on the internal compact flash card (256 MB).                    | MB         |



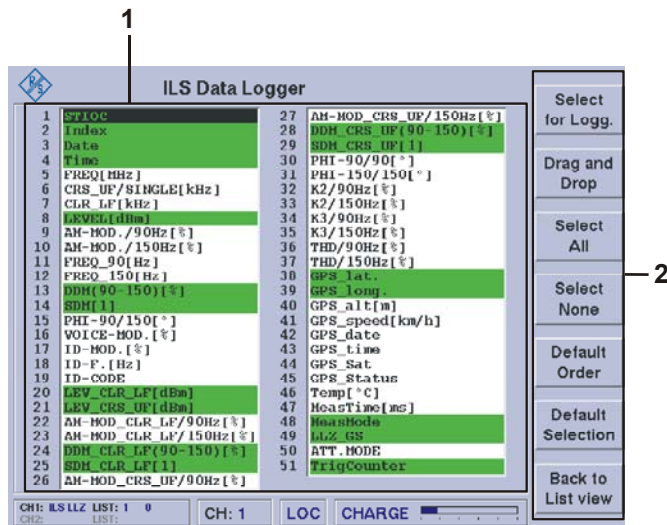

3.14.2 Signal Parameters and Display in the menu window "Parameter settings"



| Item | Display   | Function   | Indication |
|------|-----------|--|------------|
| 1    | Shortlist | A shortlist contains all parameters associated with a particular mode. From the multitude of parameters available in the shortlist, the order and the parameters can be determined, which should be stored and which should be displayed in the list. This selection determines the display of the dataset list. Selected parameters will be highlighted green. Each individual setting can be associated with a preset location. Either the rollkey or the up/down arrows may be used to navigate through the list. |            |

3.14.2.1 Softkeys (2) of the menu window " Parameter settings"

| Display          | Function  |
|------------------|---|
| Select for Logg. | Use this softkey to select and accept a parameter into the shortlist (green background) or to delete the parameter (white background).  |
| Drag and Drop    | Use this softkey to change the order of the parameter within the shortlist. To do this, select a parameter (inverse) and use the softkey to mark it (blue background), then use the rollkey to select a new position within the list. Confirm the new position by pressing the softkey again. |
| Select All       | This function selects all parameters of the shortlist. The selection will be highlighted green.   |
| Select None      | This function selects none of the parameters of the shortlist. The selection will be highlighted white. If this setting is selected, no datasets will be displayed or stored in the dataset list.   |
| Default Order    | This softkey resets the default order of all parameters in the shortlist.   |

| Display   | Function  |
|---|---|
|  | With the softkey the default shortlist is called. |
|  | Switching to the "Dataset list" window.           |

### 3.14.3 Signal Parameters and Display in the menu window "ILS-Graph"

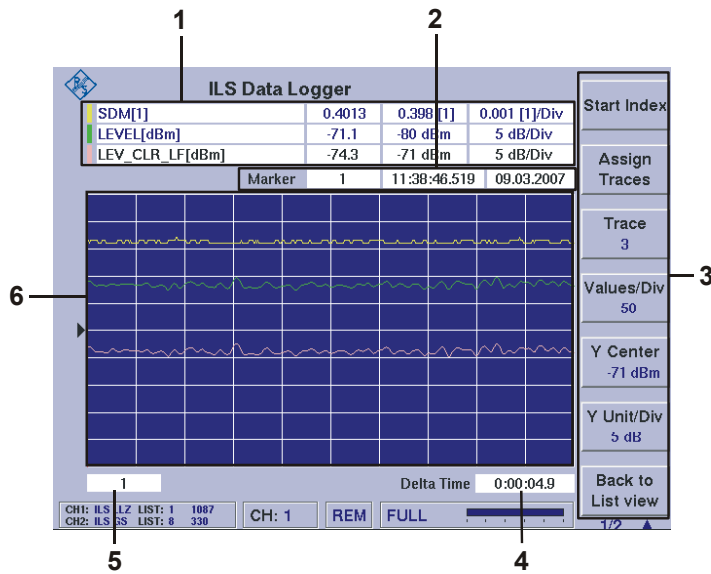







| Item | Display         | Function  | Indication   |
|------|-----------------|---|--|
| 1    | Parameter field | Displays all parameters and data, which were selected in the "Trace" window. Up to 3 different parameters may be displayed. The colour marking of the parameter line (yellow, green, and light red) corresponds with the displayed curve. The displayed data corresponds with the current Marker position.<br><br>Display within the table:<br>Measurement parameter,<br>measured value<br>Y value in diagram middle (Y center)<br>Scaling in Y direction | The display of the different units of measure depends on the selection made. |
| 2    | Marker field    | The first field contains the Marker Index; this identifies the selected measurement line of the current list. Furthermore, the date and time when the highlighted dataset was stored is also shown.   | Index No.<br>hh:mm:ss.sss<br>dd.mm.yyyy                                      |
| 3    | Softkeys        | These will be described in the following section.   |  |
| 4    | Delta Time      | Delta Time indicates the period between the first and the last displayed data.  | hh:mm:ss.sss   |



| Item | Display     | Function   | Indication |
|------|-------------|--|------------|
| 5    | Index field | Display and selection (softkey "Start Index") of the used indices (dataset) from the current dataset list. |            |
| 6    | Indication  | Graphic display of the selected parameter value set.   |            |

**3.14.3.1 Softkeys (3) of the menu window "ILS-Graph"**

| Display   | Function  |
|---|---|
|    | Activates the setting for the selection of an index (index field 5) from the dataset list. This defines the index of a dataset list, with which the graphic display should start.   |
|    | Switching to the "ILS-Graph-Trace" menu window, in order to select those parameters, which should be displayed graphically.   |
|    | Selection of the curve (Trace) for which the setting "Y Center" and "Y Unit/Div" should be carried out. The respective parameter line will be highlighted white.  |
|  | Activates the editing function to change the number of displayed data per scale division on the X axis. This will automatically determine the width of the displayed time window (Delta Time).<br>Setting range: 5, 10, 25, 50, 100, 250, 500, 1000, 2500, 5000   |
|  | Activates the editing function to change the position of the center line. By doing this, a value will be assigned to the center line of the selected Trace. The setting refers to the curve, which has been selected via the "Trace" softkey. For each Trace 1 ... 3, this value can be set individually. |
|  | Activates the editing function to change the scaling of the Y axis. This determines the unit of measure per scale division on the Y axis. The setting refers to the curve, which has been selected via the "Trace" softkey. For each Trace 1 ... 3, this value can be set individually.                   |
|  | Switching to the "Dataset list" window.   |

**3.14.3.2 Signal Parameters and Display in the menu window "ILS-Graph-Marker"**

Any display not discussed here, can be found in the description of the menu window "ILS Graph".

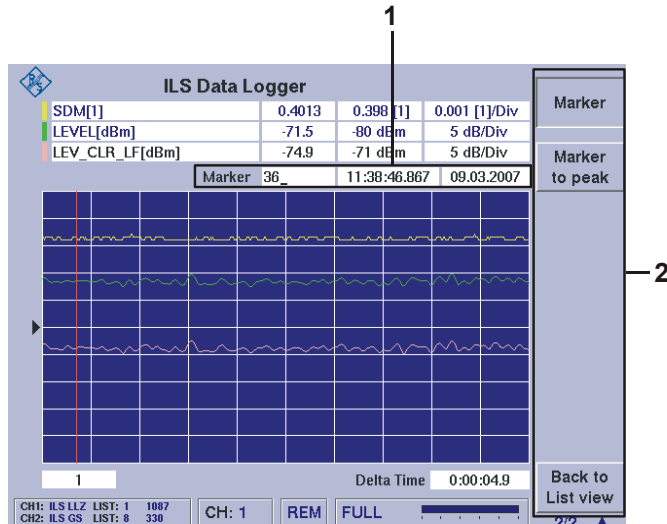

| Item | Display      | Function   | Indication                              |
|------|--------------|--|---|
| 1    | Marker field | Display and selection of the Marker Index. The editing function can be activated via the "Marker" softkey. Furthermore, the date and time when the highlighted dataset was stored is also shown. | Index No.<br>hh:mm:ss.sss<br>dd.mm.yyyy |

**3.14.3.2.1 Softkeys (2) of the menu window "ILS-Graph-Marker"**

| Display           | Function   |
|-------------------|--|
| Marker            | Activates the editing function to change the Marker setting. The Marker Index (which corresponds with the line index of the current list) can be changed in the Marker field. The Marker is displayed as a red vertical bar. |
| Marker to peak    | The Marker will be placed on the largest visible data value of that curve, which was selected via the "Trace" softkey. The table will be updated accordingly.  |
| Back to List view | Switching to the "Dataset list" window.  |

**3.14.3.3 Signal Parameters and Display in the menu window "ILS-Graph-Trace"**

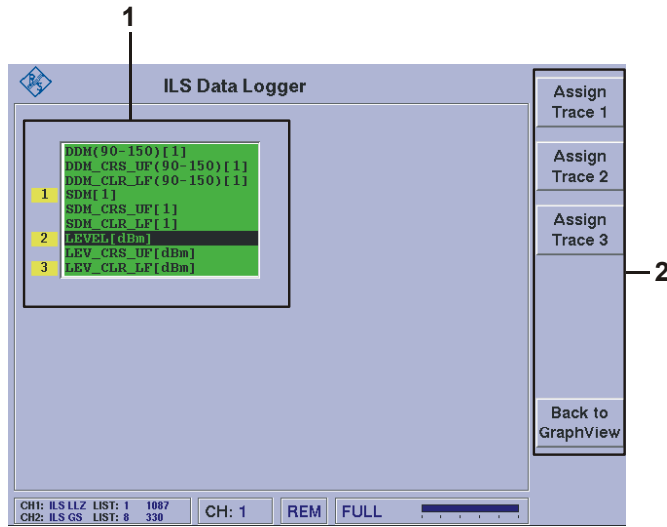

| Item | Display   | Function  | Indication |
|------|-----------|---|------------|
| 1    | Shortlist | <p>Selection of all possible parameters, which should be displayed graphically. One parameter should be selected per Trace. A yellow box with the respective trace number indicates the order and assignment to Trace 1 ... 3.</p> <p>The green background indicates the availability of the parameter in the dataset list, i.e. the parameter was selected for "Logging" in the menu window "Parameter settings" (see 3.14.2).</p> |            |

**3.14.3.3.1 Softkeys (2) of the menu window "ILS-Graph-Marker"**





| Display  | Function  |
|----------|---|
| <br><br> | <p>When using the "Assign Trace 1 ... 3" softkey, an individual parameter can be assigned from the selection window. A yellow box with the respective trace number indicates the order and assignment to Trace 1 ... 3.</p> |
|          | <p>Switching to the "Dataset list" window.</p>  |

**3.14.4 Using the Data Logger for the storage of data**



While in mode ILS, VOR, and MARKER BEACON, the Data Logger may be used to log data. The "SAVE" (42) button may be used to accept individual datasets manually into the dataset list of the preset mode, or entire measurement lines can be automatically recorded. Use the "START" button to

begin the recording of the measurement line and use the "STOP" button to stop the process. However, prior to starting a measurement line, the following settings must be activated:



### 3.14.4.1 Setting the Logging Interval Time

|    | Control   | Operation  | Function   |
|----|---|--|--|
| 1. |   | Switch to "Setup" and select the menu window "Data Logger". Select the window "Logging Interval [hour:min]". |  |
| 2. |    | Setting the corresponding Logging Interval Time (h) with rollkey / keyboard.                                 | Measurement interval setting in hours and minutes (e.g. Setting: 1 h = one measurement per hour).<br>Setting value: 00:01 ... 24:00 h<br>Depending of meas. interval (sec) |
| 3. |    | Press the Enter button / rollkey push.   | Acceptance of the new set value.   |
| 4. |   | Select the window "Logging Interval [sec]"   |  |
| 5. |  | Setting the corresponding Logging Interval Time (s) with rollkey / keyboard.                                 | Measurement interval setting in seconds (e.g. setting: 1 s = one measurement per second).<br>Setting value: 0.01 ... 59.90 s<br>Depending of meas. interval (hh:mm)        |
| 6. |  | Press the Enter button / rollkey push.   | Acceptance of the new set value.   |



### 3.14.4.2 Activation the Automatic ON / OFF function at measuring interval

|    | Control   | Operation   | Function   |
|----|---|---|--|
| 1. |   | Switch to "Setup" and select the menu window "Data Logger". Select the window "Auto Power Down".  |  |
| 2. |  | Select  | Activation of the automatic ON / OFF function at a preset measuring interval.<br>Selection: ON / OFF |
|    |   |  <b>If the time between 2 measurements exceeds 3 minutes and 59.9 seconds , the device automatically shuts off and turns back on after 2 minutes. In order to enable a meaningful Auto-Power-Down function, the interval should be set to &gt;5 min!</b> |  |





|    | Control   | Operation  | Function                            |
|----|---|--|-------------------------------------|
| 3. |  | Press the Enter button / rollkey push.<br><br> <i>If a measuring routine is started while the auto power down function is activated, the device will carry out the measurement and then immediately switch itself off. Just before the preset measuring interval is reached, the device will switch itself back on and carry out the next measurement in accordance with the preset interval before switching itself off again. This measuring rhythm will remain operational until the series of measurements is discontinued by pressing the "STOP" button!</i> | Acceptance of the new set function. |



3.14.4.3 Settings to the external Trigger mechanism of the Data Logger

|    | Control   | Operation   | Function  |
|----|---|---|---|
| 1. |   | Switch to "Setup" and select the menu window "Data Logger". Select the window "Ext. Trigger Impulse". |   |
| 2. |  | Select  | Setting the impulse slope (positive / negative) of the external trigger impulses. Immediately after receiving a trigger impulse, the measurement takes place at the trigger input.<br><br>Selection: Pos. edge / Neg. edge  |
| 3. |  | Press the Enter button / rollkey push.  | Acceptance of the new set function.   |
| 4. |   | Select the menu window "Ext. Trigger Count".  |   |
| 5. |  | Setting the corresponding value with rollkey / keyboard.  | Setting the number of external trigger impulses, which are required to initiate a trigger mechanism.<br><br>e.g. "5". After each fifth external trigger impulse one dataset will be stored in the Data Logger (logging source "ext. trigger") or in the column "STIOC" a dataset will be identified with the letter "T" (Logging Source "time + ext. Trig.").<br><br>See also Section 3.14.4.5, "Setting the control system (Logging Source)"!<br><br>Setting value: 1 ... 1000 |



|    | Control   | Operation   | Function                            |
|----|---|---|-------------------------------------|
| 6. |  | Press the Enter button / rollkey push.<br><br> <b>The external trigger settings are only effective, if in the selection window "Logging Source" the settings "ext. Trigger" or "time + ext. trig." are selected!</b> | Acceptance of the new set function. |

#### 3.14.4.4 Setting the Logging Channel

|    | Control   | Operation  | Function  |
|----|---|--|---|
| 1. |   | Switch to "Setup" and select the menu window "Data Logger". Select the window "Logging Channel". |   |
| 2. |    | Select   | Setting the receiver channel, from which the Data Logger should record the data.<br>Selection: CH 1 / CH 2 (1*),<br>CH1 + CH 2 (1*) |
| 3. |  | Press the Enter button / rollkey push.   | Acceptance of the new set function.   |

1\* if channel 2 is used as an option (otherwise, not adjustable)

#### 3.14.4.5 Setting the Logging Source

|    | Control   | Operation   | Function  |
|----|---|---|---|
| 1. |   | Switch to "Setup" and select the menu window "Data Logger". Select the window "Logging Source". |   |
| 2. |  | Select  | Setting the Data Logger control system. The control system may be selected based on time, external trigger impulses, or a combination of both. The control system determines the frequency of data recording. If a control function is selected based on time, the datasets will be stored depending on the time of the "Logging Interval". If a control function is selected based on external trigger mechanisms, the datasets will be stored depending on the trigger impulse. A system combining both methods, will mark the occurrence of an external trigger impulse in addition to the time-controlled Data Logger list. |



|    | Control | Operation                              | Function   |
|----|---------|--|--|
|    |         |  | Selection: time<br>ext. trigger<br>time + ext. trig. |
| 3. |         | Press the Enter button / rollkey push. | Acceptance of the new set function.                  |

3.14.4.6 Start / Stopp the Automatic storing of the measured value





|    | Control | Operation                      | Function  |
|----|---------|--------------------------------|---|
| 1. |         | Press the "Start" (10) button. | The automatic storing process for the measured value must be initiated manually in the set measurement mode (e.g. ILS). According to the setup measurement interval times the measured values will be entered into the Data logger. |
| 2. |         | Press the "Stop" (12) button.  | The automatic storing process for the measured value must be terminated manually in the set measurement mode (e.g. ILS).  |

3.14.5 Selection of Data set list

|    | Control | Operation   | Function   |
|----|---------|---|--|
| 1. |         | Press the softkey.  | Switching over into the edit function and selection of a data set list. The softkey value section is active.<br> |
| 2. |         | Turn the rollkey several times until the required list appears. | The current list number will be carried along numerically in the softkey.  |
| 3. |         | Press the Enter button / rollkey push.                          | Acceptance of the actually set new data set list.<br>  |

### 3.14.6 Processing a Dataset list

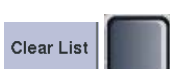
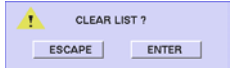
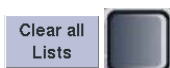
The following explains the operating steps necessary for processing a dataset list.



|   | Control   | Operation                            | Function   |
|---|---|--------------------------------------|--|
| <b>Selection of Data set line</b>                               |   |                                      |  |
| 1.  |    | Press the softkey "Select Line".     | Switching over into the edit function and selection of a data set list. The softkey value section is active.<br><br><br><br>Selection of a line takes place via rollkey / keyboard. To accept the index, press enter or rollkey push. |
| <b>Deletes the current Data set list</b>                        |   |                                      |  |
| 2.  |    | Press the softkey "Clear List".      | The current data set list is deleted after the security question has been confirmed.<br><br>   |
| <b>Deletes all Data set listings in the current device mode</b> |   |                                      |  |
| 3.  |  | Press the softkey "Clear all Lists". | All data set listings relating to the device mode set are, deleted after the security question has been confirmed.<br><br>  |

### 3.14.7 Copy the current list onto an USB-memory-stick

The following explains the operating steps necessary for copy the current list onto an USB-memory-stick.

|    | Control | Operation   | Function             |
|----|---------|---|----------------------|
| 1. |         | Insert the USB memory stick into one of the USB interfaces (29).<br><br> <b>We recommend USB memory sticks without "security feature". The USB memory sticks supplied by the Kingston company or SanDisk have demonstrated proven effectiveness.</b> | wait about 5 seconds |

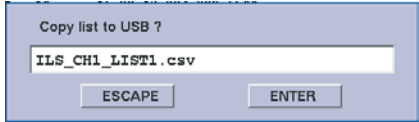

|    | Control   | Operation                               | Function  |
|----|---|---|---|
| 2. |  | Press the softkey " Copy List to USB ". | The default file name may be changed. After confirmation of a security question, the transfer of the current list in CSV file format will be started. Should any error occur during the transfer, a dialog box will be displayed.<br><br><br><br> <b>Never remove the USB memory stick during the copying process!</b> |
| 3. |   | Remove the USB memory stick.            | When the copying process is complete, wait approximately 10 seconds before removing the USB memory stick.   |

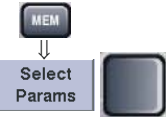
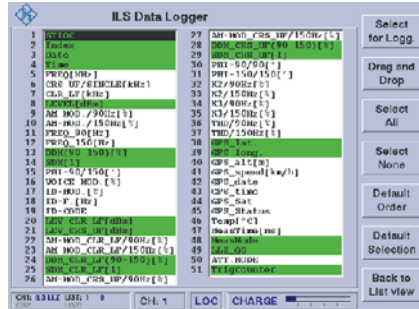

### 3.14.8 Creating an individual Dataset list

The following explains the operating steps necessary to create a individual dataset list.

|    | Control   | Operation  | Function   |
|----|---|--|--|
| 1. |  | Press the "MEM" (41) button and the softkey "Select Params". | The device switches to the Data Logger function and to the menu window "Parameter settings" of the previously set mode (e.g. ILS).<br><br> |

#### Example: Change the list order

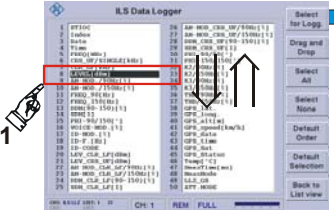
|    |   |   |  |
|----|---|---|--|
| 2. |  | Select a parameter with the rollkey and dialing with the softkey "Drag and Drop". | Using the "Drag and Drop" softkey, the order of the parameter within the selection list can be established. This will determine the order of the columns within the dataset list |
|----|---|---|--|

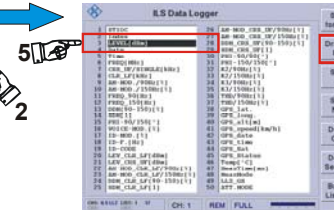
| Control  | Operation  | Function   |
|--|--|--|
| <p><b>Sequence 1</b><br/>Use the rollkey to select the parameter (1), which needs to be shifted.</p>  <p>Sequence 1</p> | <p><b>Sequence 2</b><br/>Use the "Drag and Drop" softkey (2) to mark (blue background) the selected parameter (3, inverse). Use the rollkey to position the parameter into its new location in the list.</p>  <p>Sequence 2</p> | <p><b>Sequence 3</b><br/>Confirm the new position in the shortlist by pressing the softkey (4).</p>  <p>Sequence 3</p> |

**Example: Selecting or deselecting all parameters on a list**

3.



Press the corresponding softkey "Select All" oder "Select None".

Softkey "Select All", selecting all parameter in the shortlist.

Softkey "Select None", deselecting all parameter in the shortlist.

Use the "Select All" softkey to select all parameter in the list. The selection will be highlighted green. Subsequently, all parameters in the list will be displayed and stored. Use the "Select None" to deselect all parameters of a list. The selection will be highlighted white. Subsequently, none of the parameters in the list will be displayed or stored. This is helpful, if a quick selection of parameters becomes necessary.

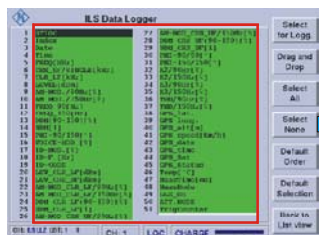

selecting all parameter

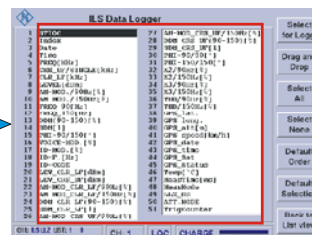

deselecting all parameter

**Example: Selecting or deselecting individual parameters on a list**

4.

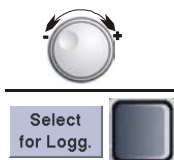

To pick out a parameter with the rollkey and select with the softkey "Select for Logg.".

Use the "Select for Logg." softkey to select a parameter and to accept it into the list (green background); use the same key to remove a parameter (white background).

**Example: Restoring the order of parameters in the list back to their default**

5.



Press the softkey "Default Order".

When using the "Default Order" softkey, the default order of the parameters in the shortlist is restored.



|  | Control | Operation | Function |
|--|---------|-----------|----------|
|--|---------|-----------|----------|

Example: Calling the default shortlist

|    |  |  |   |
|----|--|--|---|
| 6. |  | Press the softkey "Default Selection". | With the softkey "Default Selection" the default shortlist is called. |
|----|--|--|---|

3.14.8.1 Graphic display of ILS data

The following explains the operating steps necessary analyzing a ILS signal graphically.

|  | Control | Operation | Function |
|--|---------|-----------|----------|
|--|---------|-----------|----------|

Switch to window 2 of the Data Logger

|    |  |  |                                       |
|----|--|--|---------------------------------------|
| 1. |  | Press the "MEM" (41) button and softkey "Select List". | Select the dataset list for analysis. |
|----|--|--|---------------------------------------|



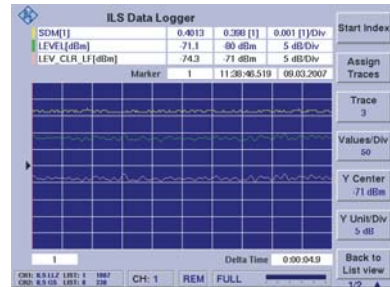



|    |  |                                 |  |
|----|--|---------------------------------|--|
| 2. |  | Press the softkey "Graph View". | Switch to the graphic display of the data. |
|----|--|---------------------------------|--|

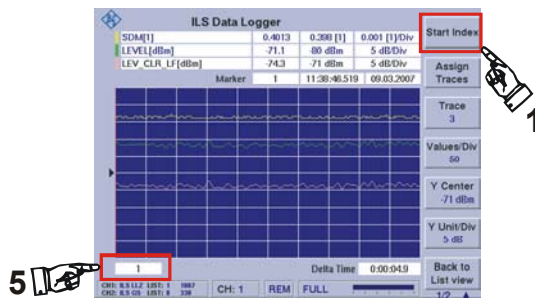

Select a dataset

|    |  |  |  |
|----|--|--|--|
| 3. |  | Activating the editing function with the softkey and making the selection over the rollkey / keyboard. | Use the softkey (1) to activate the editing function in the Index field (5). A dataset may also be selected from the current dataset list by using the index number. Within the dataset list, this selection determines the starting point of the graphic display. To accept the selection, press enter or rollkey push. |
|----|--|--|--|

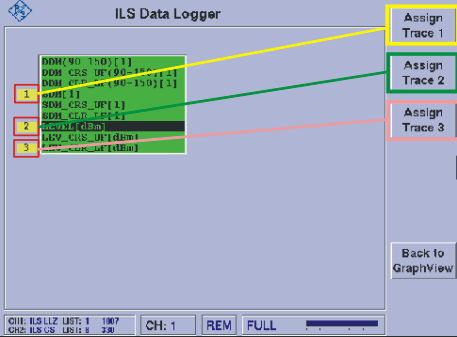
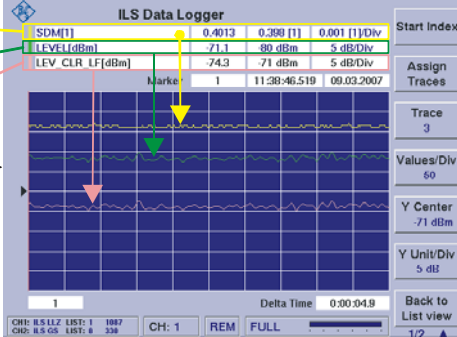

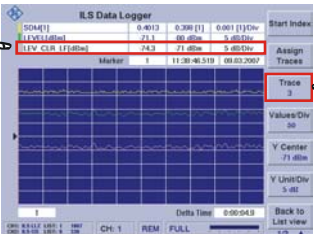
|   | Control   | Operation   | Function  |
|---|---|---|---|
| <b>Selecting parameters for the graphic display</b>   |   |   |   |
| 4.  |    | Press the softkey "Assign Traces".  | Switch to the "ILS-Graph-Trace" menu window.<br><br>  |
| 5.  | <br><br> | Select a parameter with the rollkey and refer with the softkey "Trace 1 ... 3". | A particular parameter may be assigned from the shortlist for each Trace. Use the rollkey to select a parameter, and press on the "Assign Trace 1 ... 3" softkey to assign the parameter. A yellow box with the respective trace number indicates the order and assignment to Trace 1 ... 3. This order also corresponds with the sequential values in the parameter field. |
| <div style="display: flex; justify-content: space-around;"> <div data-bbox="284 1070 743 1406">  <p style="text-align: center;">Parameter assignment</p> </div> <div data-bbox="852 1070 1311 1406">  <p style="text-align: center;">View of the graphic display</p> </div> </div> |   |   |   |
| 6.  |    | Press the softkey "Graph View".   | Returning to the graphic display.   |
| 7.  |    | Press the softkey "Trace".  | Selecting previously defined Traces 1 ... 3.  |
| <p>The data of the selected Trace will be highlighted in the parameter field (2). The currently active Trace will be displayed in the softkey (1).</p> <div style="text-align: center;">  </div>   |   |   |   |



|  | Control | Operation | Function |
|--|---------|-----------|----------|
|--|---------|-----------|----------|

**Placing the Marker**

8.

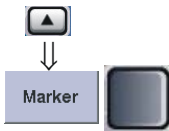

Switch to the second menu display and press the softkey "Marker".

Switching to the menu window "ILS-Graph-Marker"

Use the "Marker" softkey (2) to activate the editing function for the Marker Index (4). With this function, the Marker Index - i.e. the selected measurement line in the current list - is selected via the rollkey. The Marker (3) is placed onto the appropriate position on the graphic display. During the setting, the data of the Marker position will be updated dynamically in the DDM parameter field (1). Furthermore, the date and time when the dataset was marked in the Marker field (4) and when this information was stored is also shown.

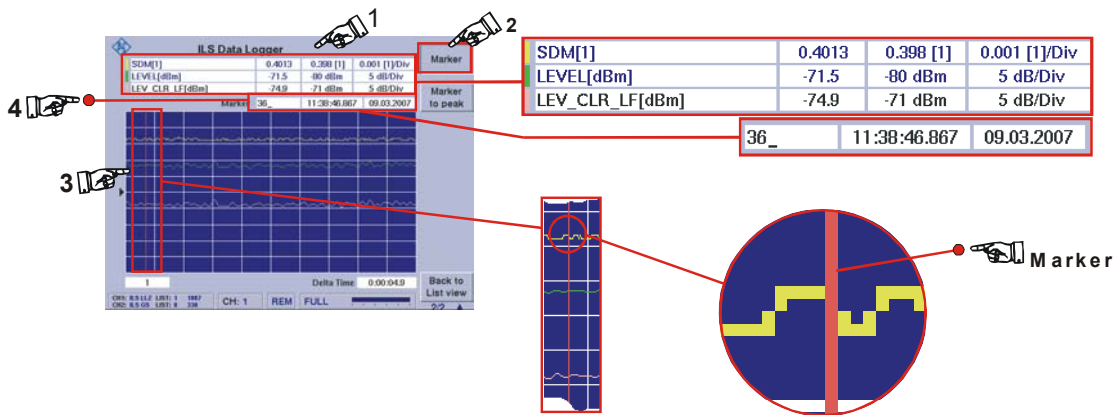

**Placing the Marker on the DDM peak value**

9.



Press the softkey "Marker to peak".

Places the Marker (3) on the peak value of the curve associated with the current Trace. The index of the peak value and the associated data will be displayed in the parameter field (1) or the Marker field (4).

**Setting the display resolution**

10.



Press button.

Returning to the first menu window "ILS-Graph".

11.

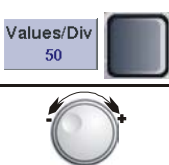

Press the softkey "Values/Div" and put through the setting with rollkey.

The softkey (1) activates the settings for the display resolution of the X axis.

12.

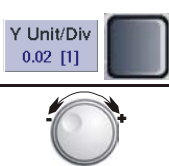

Press the softkey "Y Unit/Div" and put through the setting with rollkey.

The softkey (3) activates the editing function for the settings of the Y axis.



|     | Control   | Operation  | Function  |
|-----|---|--|---|
| 13. |  | Press the softkey "Y Center" and put through the setting with rollkey. | The softkey (2) activates the editing function for the settings of the the center line of the Y axis. |

**Setting the display resolution of the X axis:** select the number of data per scale division on the X axis. This will automatically determine the width of the displayed time window (Delta Time, 4). The set value will be displayed in the softkey.

Setting range: 5, 10, 25, 50, 100, 250, 500, 1000, 2500, 5000 / data per scale division

**Setting the Y axis:** Set the unit of measure per scale division on the Y axis. When selecting the units of measure for the parameter, its DDM and SDM values can be set to  $\mu\text{A}$ , %, or 1. To do this, use the setup function "Units". The scaling of level values is always expressed in dB. The scaling can be set individually for each Trace 1 ... 3.

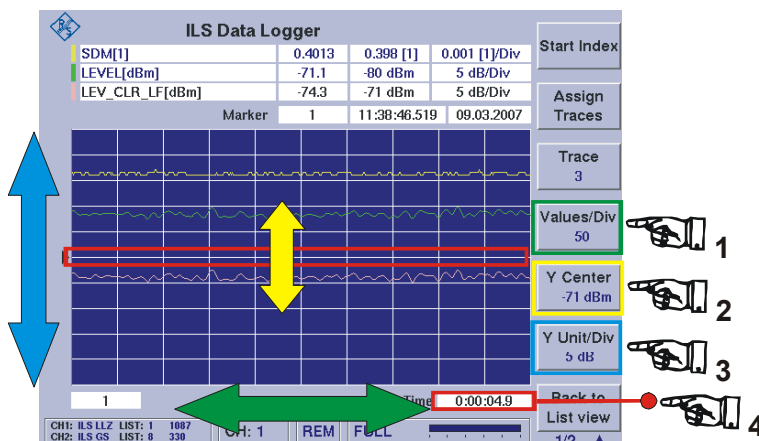

**Setting the center line of the Y axis:** This assigns a certain value to the centerline of a selected Trace, and allows shifting the position of the data curve in the Y direction. When selecting the units of measure for the parameter, its DDM and SDM values can be set to  $\mu\text{A}$ , %, or 1. To do this, use the setup function "Units". Level values can be selected with the setup function and determined either as dBm or dB $\mu\text{V}$ . The Y-Center can be set individually for each Trace 1 ... 3.









### 3.15 Preset mode operation

The preset function enables 20 different individual device settings to be saved and used. This pre - settings includes operational settings for a mode (such as frequency, channel etc.) and the most important set up settings. If a particular device setting is stored, date and time are automatically assigned to the list's element. Each element of a list may be named individually.

|    | Control   | Operation                  | Function  |
|----|---|----------------------------|---|
| 1. |  | Press the "Preset" button. | The display switches over into the Preset mode.<br> |

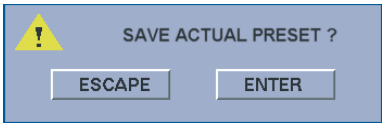





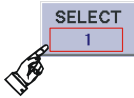

#### Call-up a preset

|    |   |                             |  |
|----|---|-----------------------------|--|
| 2. |   | Press the softkey "SELECT". | Change to editing function to select a "UserPreset-No.". The softkey value section is active.<br><br>Selection of a "UserPreset-No." is activated via the rollkey / keyboard. To accept the value, press enter or rollkey push. |
| 3. |  | Press the softkey "SAVE".   | The current device settings will be saved to the selected "UserPreset-No." with the current date / time after the security question has been confirmed.<br>  |

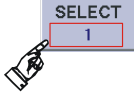
 **Assignment of a saved presetting is indicated by a date / time entry. Available memory has no date / time entry. Assigned memory can be rewritten any number of times!**

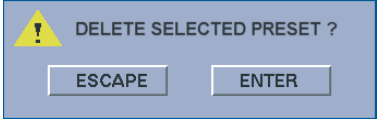
#### Retrieval a preset

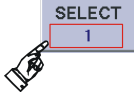
|    |   |                             |  |
|----|---|-----------------------------|--|
| 4. |  | Press the softkey "SELECT". | Change to editing function to select a "UserPreset-No.". The softkey value section is active.<br><br>Selection of a "UserPreset-No." is activated |
|----|---|-----------------------------|--|

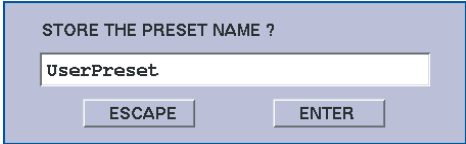
|                                | Control   | Operation                   | Function  |
|--------------------------------|---|-----------------------------|---|
|                                |   |                             | via the rollkey / keyboard. To accept the value, press enter or rollkey push.   |
| 5.                             |    | Press the softkey "RECALL". | <p>The current device settings will be rewritten with the pre-settings of the selected "User-Preset-No." after the security question has been confirmed.</p>    |
| <b>Delete a preset</b>         |   |                             |   |
| 6.                             |    | Press the softkey "SELECT". | <p>Change to editing function to select a "UserPreset-No." to be deleted.</p>  <p>Selection of a "UserPreset-No." is activated via the rollkey / keyboard. To accept the value, press enter or rollkey push.</p>         |
| 7.                             |  | Press the softkey "DELETE". | <p>The selected "UserPreset-No." will be deleted after the security question has been confirmed.</p>    |
| <b>Renaming a list element</b> |   |                             |   |
| 8.                             |  | Press the softkey "SELECT". | <p>Change to editing function to select a "user settings number" to be renamed.</p>  <p>Selection of a "UserPreset-No." is activated via the rollkey / keyboard. To accept the value, press enter or rollkey push.</p> |
| 9.                             |  | Press the softkey "RENAME". | <p>After the selection, a dialog box appears, which lists the previous name.</p>    |



|     | <b>Control</b>  | <b>Operation</b>                             | <b>Function</b>   |
|-----|---|--|---|
| 10. |  | Renaming with arrow buttons and the keyboard | Use the up/down arrow button and the keyboard to edit the respective name. Use the "ENTER" key to accept and store the current list element and its newly created name. To abort the process, press the "ESCAPE" button any time. |

**Call-up of the factory settings**

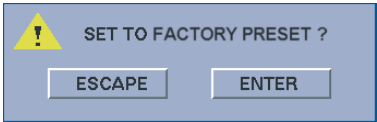
|     |   |                                     |   |
|-----|---|-------------------------------------|---|
| 11. |  | Press the softkey "FACTORY PRESET". | The current device settings will be overwritten with the default settings after the security question has been confirmed.<br> |
|-----|---|-------------------------------------|---|

### 3.16 The Auto Calibration

Auto calibration corrects changes in the attenuation characteristics of the RF signal paths. These changes can occur due to the aging process or temperature drifts. The calibration optimizes the accuracy of the level measurements.



**Auto calibration should generally be carried out weekly, or more often in the event of significant fluctuations in temperature. Auto calibration is a means for optimization of the measurement analysis; however, a major calibration must be done once a year in order to optimize the static calibration data.**

#### Activates the Auto calibration

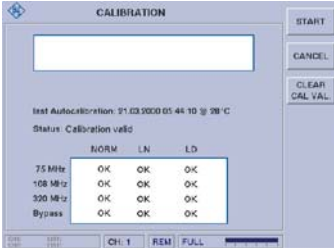
|    | Control   | Operation                    | Function  |
|----|---|------------------------------|---|
| 1. |  | Press the "CAL" (44) button. | The device switches over into the auto calibration function.<br><br> |

#### 3.16.1 Displays in calibration menu

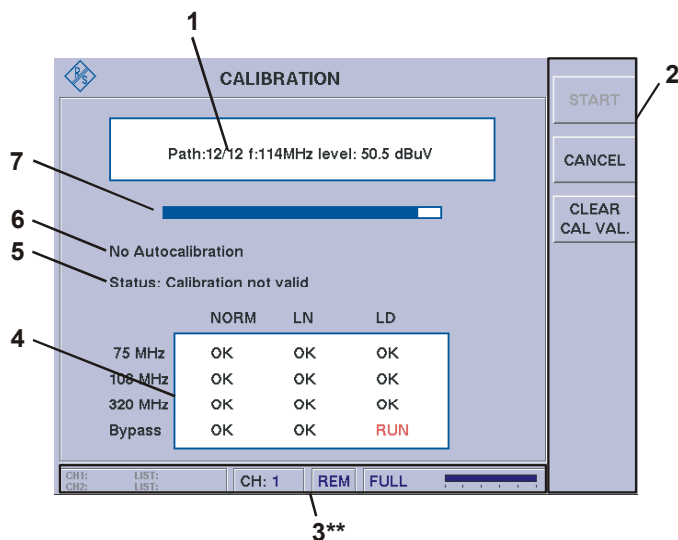



3\*\* for general description of the status field see 3.2.1.1

| Item | Display       | Function  | Indication |
|------|---------------|---|------------|
| 1    | Output window | Display of the currently performed measurements (linearity or signal path with frequencies) including the respective measurement results. |            |



| Item | Display              | Function  | Indication                  |
|------|----------------------|---|-----------------------------|
| 2    | Softkeys             | see 3.16.1.1  |                             |
| 3**  | Status field         | 3** for general description of the status field see 3.2.1.1.  |                             |
| 4    | Status window        | Display of the measurement status of the twelve individual RF-signal paths.<br>Matrix: 3 attenuator modes x 4 preselector-paths   |                             |
| 5    | Measurement status   | Display of the current measurement status.  |                             |
| 6    | Last Autocalibration | Entry of date, time and temperature (during the calibration) of the device's last auto calibration. The temperature of the device is approx. 10° C higher than the ambient temperature. | dd.mm.yyyy, hh:mm:ss;<br>°C |
| 7    | Progress graph       | Graphic representation of the progress of auto calibration.   |                             |

**3.16.1.1 Softkeys**

| Display   | Function   |
|---|--|
|  | Starts an auto calibration of the device   |
|  | Cancel an ongoing auto calibration   |
|  | Deleting the calibration values as well as the status indications in the status window |

**3.16.2 Auto Calibration operating**

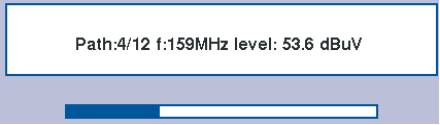
|                                  | Control   | Operation                  | Function  |
|----------------------------------|---|----------------------------|---|
| <b>Starting Auto calibration</b> |   |                            |   |
| 1.                               |  | Press the softkey "START". | Starting the auto calibration; the respective parameters and their values are displayed in the output window. The bargraph shows the progress of the calibration.<br><br> |

If the auto calibration is successful, it will be displayed in the output window (1) as "Autocalibra-

|  | Control | Operation | Function |
|--|---------|-----------|----------|
|--|---------|-----------|----------|

tion Ready!" Simultaneously, the date, time and the temperature of this calibration will be updated in the display window "last Autocalibration (6)". The respective calibration data will be displayed in the status window (4) as "OK".

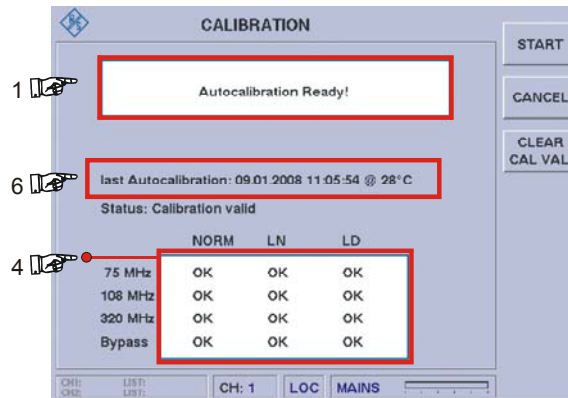

***In the event of a faulty auto calibration process, this is indicated in the status display window by "Auto calibration Error!". In this case, the device should be switched off and on again and the auto calibration process should be repeated. If the error message continues to appear, the device should be dispatched to the Rohde & Schwarz Service Department!***

### Cancel Auto calibration

2.

CANCEL

Press the softkey "CANCEL".

Stopping an ongoing auto calibration. This is indicated in the status display window by "Auto calibration Aborted". In this case, no changes are made to the device. All information of the last auto calibration will be deleted and replaced by the display "No Autocalibration" (6). The respective status messages will be deleted from the status window (4).

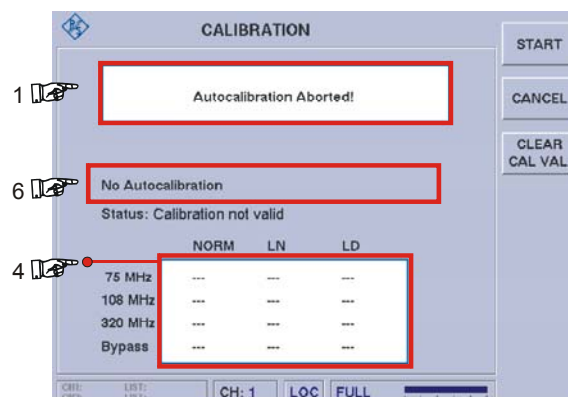



|  | Control | Operation | Function |
|--|---------|-----------|----------|
|--|---------|-----------|----------|

**Deleting the calibration values**

3.

CLEAR  
CAL VAL.

Press the softkey "CLEAR CAL VAL."

Deleting the calibration values of the last auto calibration.

All information regarding the last auto calibration will remain in the display "last Auto-calibration (6)". The respective status messages will be deleted from the status window (4) and the R&S® EVS 300 will only process the static calibration values.

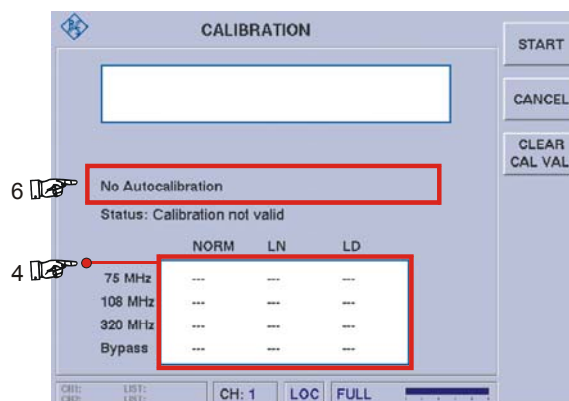





### 3.17 GPS function (Option)

The GPS function enables the indication of the current position and corresponding parameters, which were gained from the dataset of the NMEA protocol. A GPS receiver needs to be connected to the GPS interface (RS 232-2 (7)) for this purpose. The GPS data are added to the corresponding data record when automated recording of values measured is carried out.

#### 3.17.1 GPS operating (Option)

|    | Control   | Operation                   | Function  |
|----|---|-----------------------------|---|
| 1. |  | Press the "GPS" (7) button. | The device switches over into the GPS function window.<br><br> |

#### Setting the baud rate of the RS 232-2 interface

|    |   |  |   |
|----|---|--|---|
| 2. |  | Hold the softkey "Baudrate" depressed until the wanted value is reached. | The set baud rate will be updated in the softkey and is then immediately active.<br>Setting value: 4800 ... 115200 baud |
|----|---|--|---|

#### 3.17.2 Displays in the GPS menu

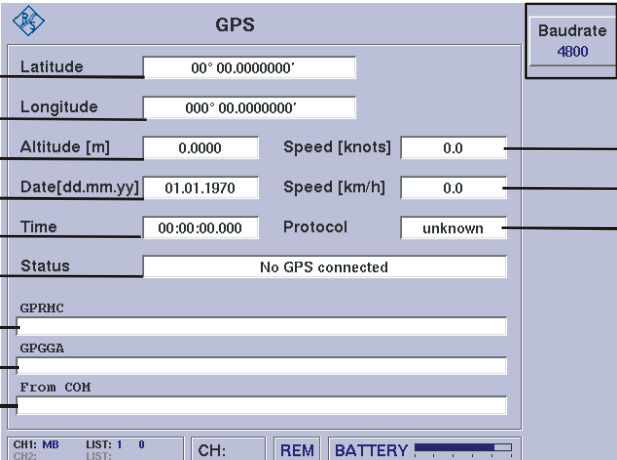

The screenshot shows the GPS menu with the following callouts:

- 1: Baudrate 4800 softkey
- 2: Speed [knots] field
- 3: Speed [km/h] field
- 4: Protocol field
- 5: From COH field
- 6: GPXGGA field
- 7: GPRMC field
- 8: Status field (No GPS connected)
- 9: Time field
- 10: Date[dd.mm.yy] field
- 11: Altitude [m] field
- 12: Longitude field
- 13: Latitude field



| Item | Display       | Function                    | Indication |
|------|---------------|-----------------------------|------------|
| 2    | Speed [knots] | Indication of speed (knots) | knots / h  |



| Item | Display      | Function   | Indication |
|------|--------------|--|------------|
| 3    | Speed [km/h] | Indication of speed (km/h)   | km/h       |
| 4    | Protocol     | Indication of the GPS protocol, e.g. NMEA (National Marine Electronics Association)  |            |
| 5    | From COM     | Arriving data from the serial interface (GPS RS 232-2, 7).   |            |
| 6    | GPGGA        | <p>GPGGA (Global Positioning System Fix Dat) dataset containing the most important information of the GPS position and accuracy. They will be displayed as ASCII character set with 4.800 baud and in the following format:</p> <p>\$GPGGA,hhmmss.ss, llll.ll,a,yyyy.yy,b,q,nn,d,d,a,a,M,g,g,M,h,h,rrrr*hh</p> <ul style="list-style-type: none"> <li>a. hhmmss.ss = current time (UTC)</li> <li>b. llll.ll = Latitude detail</li> <li>c. a = Hemisphere of latitude N (north) / S (south)</li> <li>d. YYYYY.YY = Longitude detail</li> <li>e. a = Hemisphere of longitude E (east) / W (west)</li> <li>f. q = GPS-quality</li> <li>g. nn = Number of used satellites (0 ... 12)</li> <li>h. d.d = Horizontal deterioration of the position</li> <li>i. a.a = Height of the antenna</li> <li>j. M = Unity of the antenna height in meter (m)</li> <li>k. h.h = Age of the DGPS data</li> <li>l. rrrr = DGPS-reference station (0000 ... 1023)</li> <li>m. hh = Checksum</li> </ul> |            |
| 7    | GPRMC        | <p>GPRMC (Global Positioning Recommended Minimum Specific) means, a GPS receiver with NMEA protocol should display a dataset with the least amount of information. This dataset will be displayed as ASCII character set with 4.800 baud and in the following format.</p> <p>\$GPRMC,hhmmss.ss,A,llll.ll,a,yyyy.yy,a,x.x,x.x,ddmmyy,x.x,a*hh</p> <ul style="list-style-type: none"> <li>n. hhmmss.ss = current time (UTC)</li> <li>o. A = Status (A=ok, V=warning)</li> <li>p. llll.ll = Latitude detail</li> <li>q. a = Hemisphere of latitude N (north) / S (south)</li> <li>r. YYYYY.YY = Longitude detail</li> <li>s. a = Hemisphere of longitude E (east) / W (west)</li> <li>t. x.x = Speed into knots</li> <li>u. x.x = Direction in degree</li> <li>v. ddmmyy = Date</li> <li>w. x.x = magnetic deviation</li> <li>x. a = E (east) / W (west)</li> <li>y. hh = Checksum</li> </ul>   |            |
| 8    | Status       | GPS status and number of satellites detected   |            |
| 9    | Time         | Indication of the current Time   | hh.mm.ss   |
| 10   | Date         | Indication of the current Date   | dd.mm.yyyy |
| 11   | Altitude [m] | Indication of the current altitude   | m          |
| 12   | Longitude    | Indication of the Longitude  | [°] Degree |
| 13   | Latitude     | Indication of the Latitude   | [°] Degree |

### 3.18 Release of Software Options

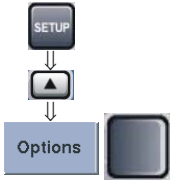
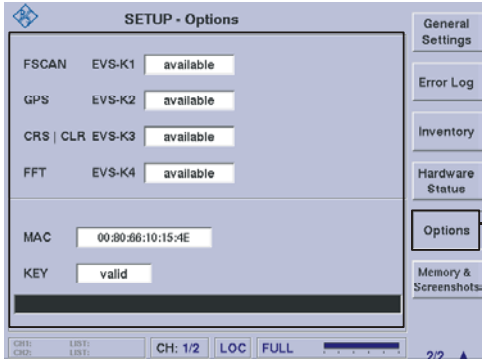
A license key for the purchased options can be entered via the options window. Once the option has been purchased, Rohde & Schwarz will provide you with the necessary key number in writing.

|    | Control   | Operation  |   |
|----|---|--|---|
| 1. |    | Press the "Setup" button and change to the window 2 and press softkey "Options" (1). | Switching to the "Options" menu window. This function displays the device-specific optional extensions.<br> |
| 2. |  | Press the Enter button / rollkey push.   | The editing function for the entry of the key number is activated and the key number received can be entered.   |
| 3. |  | Press the Enter button / rollkey push.   | Transfer of the key number. The option purchased is activated.  |



***If activation of the option does not take place, check initially that the window "Key" is displaying the entry "valid". If this is not the case, an error has been made in entering the key number, and the procedure needs to be repeated.***

### 3.19 Operation within the R&S® EVS 300 Web interface

If the R&S® EVS 300 is operated as part of a LAN network or as a stand-alone computer (PC / laptop), it can be remotely controlled via the web interface. For this, the R&S® EVS 300 requires a defined IP address and an associated subnetwork. If the R&S® EVS 300 is operated as a stand-alone computer, the device must be connected with a coaxial LAN cable. If using an internet browser, such as "MS Internet Explorer", the web interface of the device can be called up. While using the web interface, settings for the individual modes, such as ILS, VOR, MARKER BEACON, Data Logger, and Setup can be carried out and data can be called up. The display of the web interface can vary, depending on the mode.

| Item | Function  |
|------|---|
| 1    | Updating the web indication.  |
| 2    | The currently active Attenuator mode, also at Attenuator mode "Auto" is shown to it corresponding adjusted Attenuator mode.                                 |
| 3    | Starting or stopping a series of measurements over the buttons "start" and "stop". Buttons are mode-dependant.  |
| 4    | Information window of the Data Logger, with the "set" button to select an active list.  |
| 5    | Indication of the date and the time of the device.  |
| 6    | Indication the temperature of the device.   |
| 7    | GPS parameter window, displays all evaluated GPS data.  |
| 8    | Information window of the mode-specific data.   |
| 9    | General settings of the set device mode, e.g.: "ILS" via pull-down menu. Use the "set" button to adjust the receiving frequency and the measurement period. |
| 10   | Display of the set device mode  |

**3.19.1 Call-up the Web interface**

| Function |   |
|----------|---|
| 1.       | Use an appropriate LAN cable to connect the R&S® EVS 300 with either the LAN network or a stand-alone computer.   |
| 2.       | In the setup function of the R&S® EVS 300, go to the menu item "Remote Control" and select or replace the TCP / IP address with a new one.  |
| 3.       | Call up an Internet browser, e.g.: "MS Internet Explorer", on your computer and enter the IP address (1) of the R&S® EVS 300 into the browser's address bar, confirm your input by pressing the "Enter" button. The Internet browser should now change to the R&S® EVS 300 web interface (2). |

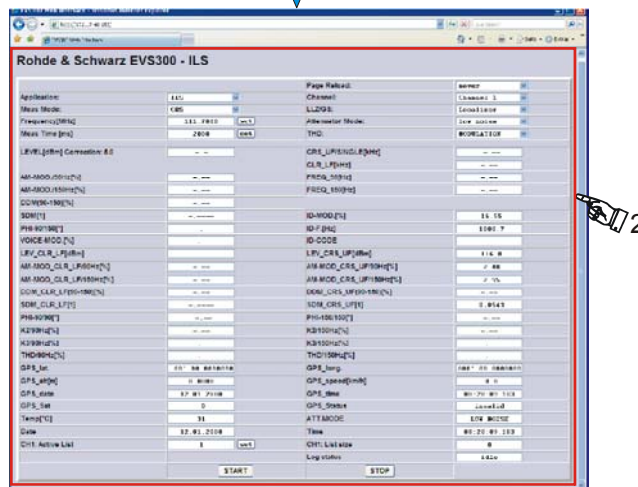
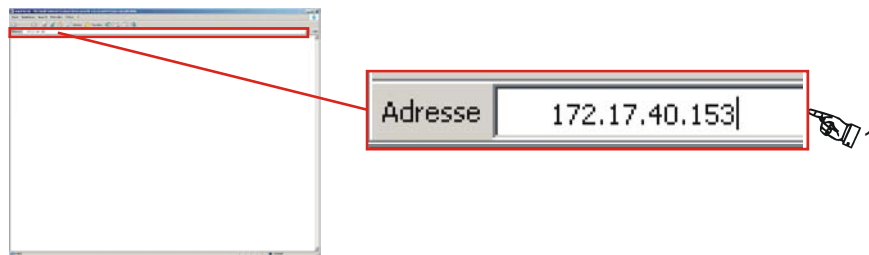



### 3.20 Remote Control of the R&S® EVS 300 ILS / VOR Analyzer

#### 3.20.1 Operation via RS-232 interface

All important unit functions of the **R&S® EVS 300 ILS / VOR Analyzer** can be remote controlled via the RS-232-Interface (V24 standard) by a PC terminal which can be operated with commercial terminal programs (e.g. HyperTerm™, ProCommPlus...). The interface parameters are adjustable in the setup.



*If measuring time is set at >50 ms, a baud rate of up to 19200 baud should be set. If the baud rate is set at 115200 baud, shorter measuring times can be set (10 ms).*

#### 3.20.2 Operation via LAN interface

Through the **LAN connection (Fast Ethernet) (9)**, all functions of the device and the data transfer of the measurement data of the **R&S® EVS 300 ILS / VOR Analyzer** can be remotely operated from a PC / network. IP Addresses and subnet mask identifier are set in the setup menu.

#### 3.20.3 Remote Control Commands

There are two categories of control commands.

- super commands (mode related)
- mode dependant commands (specified mode must first be selected)

The following table makes clear the control commands structure.

|                                      |  |          |                       |                   |            |
|--------------------------------------|--|----------|-----------------------|-------------------|------------|
| <b>Mode related control commands</b> | <b>Mode dependant control commands</b> |          |                       |                   |            |
|                                      | ILS mode                               | VOR mode | MARKER<br>BEACON mode | Data Logg<br>mode | Setup mode |

#### 3.20.3.1 Mode related Control Commands

| Command        | Parameter | Response  | Function                                   |
|----------------|-----------|-----------|--|
| FACTORY_PRESET |           | READY     | R&S® EVS 300 back to its initial settings. |
| BI, BI?        |           | <BI-Info> | Built-in-test information.                 |
| CH             | 1<br>2    | READY     | Selection of the receiving channel 1 / 2.  |

| Command                               | Parameter                              | Response   | Function   |
|---------------------------------------|--|------------|--|
| CH?                                   |  | 1<br>2     | Request of the current receiving channel.  |
| GETDATADEF                            |  | definition | Definition of data delivered by GETDATASET<br>The text is identical to the first row of a CSV-list exported to USB. The dataset depends on the mode and Data Logger settings, e.g.: "Select Params".   |
| GETDATA SET                           |  | All values | All measurement values are returned as one comma separated string. Format is the same as one row of the CSV-list exported to USB. Works for ILS, VOR, MB.  |
| GETMEAS<br>Example:<br>GETMEAS FULL,1 | FULL,<br>SELECT,<br>SHORT<br>1, 2, 1+2 | READY      | Starts the data output in the current mode with the following options:<br><br><b>FULL:</b><br>All possible data of the current mode will be displayed as comma-separated values<br><br><b>SELECT:</b><br>Only those data of the current mode will be displayed as comma-separated, which were previously selected under the Data Logger setting "Select Params".<br><br><b>SHORT:</b><br>Only the most important data of a mode will be displayed as comma-separated. Data Logger settings under the function "Select Params" do not affect the data output. The following data of the measuring modes will be displayed:<br><br><b>ILS parameters:</b><br>Mode-specific, only a portion of the following parameter will be measured. Data, which has not been measured will be displayed as "-- --"<br>Channel, Time after start in ms, Level, Level CRS, Level CLR in dBm, DDM, DDM CRS, DDM CLR in [1], SDM, SDM CRS, SDM CLR in [1], GPS Latitude, GPS Longitude |



| Command                          | Parameter                         | Response                | Function   |
|----------------------------------|-----------------------------------|-------------------------|--|
|                                  |                                   |                         | <p><b>VOR</b> parameters:<br/>           Channel, Time after start in ms,<br/>           Level in dBm,<br/>           Bearing in [°],<br/>           Mod 30 Hz, Mod 9960 Hz in [%],<br/>           FM Deviation in Hz,<br/>           GPS Latitude, GPS Longitude</p> <p><b>MARKER BEACON</b> parameters:<br/>           Channel, Time after start in ms,<br/>           Level in dBm,<br/>           Mod 400 Hz, Mod 1300 Hz,<br/>           Mod 3000 Hz in [%],<br/>           Mod ID in [%],<br/>           GPS Latitude, GPS Longitude</p> |
| GETMDEF                          | FULL,<br>SELECT,<br>SHORT<br>1, 2 | definition              | Definition of data delivered by GETMEAS. The text is identical to the first row of a CSV-list exported to USB.   |
| GETOPTIONS                       |                                   | e.g. "F SCAN",<br>"GPS" | Request the released software option.  |
| GETTEMP                          |                                   | Values                  | Request the temperature of the main board, RF1 and RF2-Board.  |
| GETTVR<br>Example:<br>GETTVR RF1 | RF1, RF2                          | READY                   | Request the RF board calibration data.   |
| INV, INV?                        |                                   | <Inv-Info>              | Request of the serial number (unit and modules).   |
| LA, LA?                          |                                   | <dBm>                   | Request of the receiver level.   |
| LO                               |                                   | READY                   | The device moves back into the local usability at a previous inhibition of the local usability by the command "REMOTELOCK".  |
| M?                               |                                   | ILS<br>VOR<br>MB        | Request of the current set mode.   |
| MARKSTREAM                       |                                   | READY                   | In the running stream output the "S" flag is set. Only visible in "FULL" or "SELECT" stream.<br>(also see command "SREAM")   |
| MB                               |                                   | READY                   | Activates the MARKER BEACON mode.  |



| Command                              | Parameter                              | Response                          | Function  |
|--------------------------------------|--|-----------------------------------|---|
| MEASTIME<br>Example:<br>MEASTIME 100 | Time in ms                             | READY.                            | Setting the measurement time in the active mode.  |
| MEASTIME?                            |  | Time in ms<br>Example:<br>100 ms  | Request the current measurement time settings of the current mode.  |
| MI                                   |  | READY                             | Activates the ILS mode.   |
| MV                                   |  | READY                             | Activates the VOR mode.   |
| REMOTELOCK                           | ON, OFF                                | READY                             | IF set to "ON", no local operation by keyboard is possible. The "LOCAL" button has no effect. To leave this state, the device must be set to "REMOTELOCK OFF" or must be restarted. |
| RF<br>Example:<br>RF 108150          | <freq in kHz>                          | READY                             | Sets the frequency.   |
| RF?                                  |  | <freq in kHz><br>e.g. "RF 108150" | Request of the current receiving frequency.   |
| SETATTMODE                           | AUTO<br>LN<br>NORM<br>LD               | READY                             | Selects the ATT mode in the current mode.   |
| SQUELCH<br>Example:<br>SQUELCH -90.5 | Squelch in dBm                         | READY                             | Sets the squelch level in the current mode.   |
| SQUELCH?                             |  | <[dBm]>                           | Request of the squelch level in the current mode.   |
| STOPSTREAM                           |  | READY                             | Ends the output.  |
| STREAM<br>Example:<br>STREAM FULL,1  | FULL,<br>SELECT,<br>SHORT<br>1, 2, 1+2 | READY                             | See command "GETDATASET" and "GETMEAS".   |
| VER,VER?                             |  | <sw-version>                      | Request of the software version.  |



**3.20.3.2 Remote Control Commands of the ILS mode**

| Command | Parameter | Response                | Function  |
|---------|-----------|-------------------------|---|
| AC8     |           | <CODE>                  | Request of the identifier CODE.   |
| AF2     |           | <Hz><br>e.g. "90.01Hz"  | Request of the AF frequency of 90-Hz signal in Hz.  |
| AF3     |           | <Hz><br>e.g. "150.02Hz" | Request of the AF frequency of 150-Hz signal in Hz.   |
| AF8     |           | < Hz >                  | Request of the AF frequency of identifier in Hz.  |
| AM2     |           | < [%]>                  | Request of the AM-modulation factor of 90-Hz signal in %.   |
| AM3     |           | < [%]>                  | Request of the AM-modulation factor of 150-Hz signal in %.  |
| AM8     |           | <%>                     | Request of the AM-modulation factor of identifier in %.   |
| AM9     |           | <%>                     | Request of the AM-modulation factor of Voice signal in %.   |
| DCLR    |           | <DDM_CLR [1]>           | Request of the current DDM Clearance value (dimensionless).   |
| DCRS    |           | <DDM_CRS [1]>           | Request of the current DDM Course value (dimensionless).  |
| DD0     |           | <DDM [1]>               | Request of the current DDM value (dimensionless).   |
| DD1     |           | <DDM [µA]>              | Request of the current DDM value in µA.   |
| FA0     |           | READY.                  | Stops the continuous output that was started with FA1, FA2, FA4, FA5.   |
| FA1     |           | READY.                  | Activates the continuous output of DDM / level measurement results. The output rate is defined by the current measurement interval time. Values are separated by a TAB (ASC 09).<br>DDM [1]<br>RF level [dBm] |

| Command  | Parameter                             | Response                 | Function   |
|----------|---------------------------------------|--------------------------|--|
| FA2      |                                       | READY.                   | Activates the continuous repetition of a set of values. The output rate is defined by the current measurement interval time. All values are transmitted as integer values, multiplied with a constant factor:<br>DDM [1], factor: 10000<br>RF level [dBm], factor: 10<br>AM-Mod90 [%], factor: 100<br>AM-Mod150 [%], factor: 100 |
| FA4      |                                       | READY.                   | Same as FA1, but output is preceded by a measurement time.   |
| FA5      |                                       | READY.                   | Same as FA1, but output is preceded by the time in ms since the FA5 is started.  |
| MEASMODE | CRS+CLR<br>COURSE<br>CLEAR<br>CRS CLR | READY                    | Selects the measurement mode.  |
| PH       |                                       | <DEG>                    | Request of the phase shift<br>90Hz / 150Hz (degree).   |
| SD0      |                                       | <SDM [1]>                | Request of the current SDM value (dimensionless).  |
| SD1      |                                       | <SDM [µA]>               | Request of the current SDM value (µA).   |
| FCLR     |                                       | <Hz><br>e.g. "-8000.3Hz" | Request of the current frequency Clearance value in Hz.  |
| FCRS     |                                       | <Hz><br>e.g. "8000.2Hz"  | Request of the current frequency Course value in Hz.   |
| FSINGLE  |                                       | <Hz><br>e.g. "31.2Hz"    | Request of the current frequency Single value in Hz.   |
| GS       |                                       | READY.                   | Setting the GS mode.   |
| K2_150   |                                       | <%>                      | Request of the K2 distortion value of 150-Hz signal in %.  |
| K2_90    |                                       | <%>                      | Request of the K2 distortion value of 90-Hz signal in %.   |
| K3_150   |                                       | <%>                      | Request of the K3 distortion value of 150-Hz signal in %.  |



| Command    | Parameter   | Response      | Function  |
|------------|---|---------------|---|
| K3_90      |   | <%>           | Request of the K3 distortion value of 90-Hz signal in %.                          |
| LCLR       |   | <dBm>         | Request of the current Level Clearance value in dBm.                              |
| LCRS       |   | <dBm>         | Request of the current Level Course value in dBm.                                 |
| LLZ        |   | READY.        | Setting the LLZ mode.   |
| MEASMODE   | CRS+CLR_MOD<br>COURSE_MOD<br>CLEAR_MOD<br>CRS CLR_MOD<br>SINGLE_MOD<br>CRS+CLR_THD<br>COURSE_THD<br>CLEAR_THD<br>SINGLE_THD | READY         | Setting of a measuring mode.  |
| PH         |   | <DEG>         | Request of the phase shift 90 Hz / 150 Hz in degree.                              |
| PH_150_150 |   | <DEG>         | Request of the phase shift 150 Hz / 150 Hz in degree.                             |
| PH_90_90   |   | <DEG>         | Request of the phase shift 90 Hz / 90 Hz in degree.                               |
| SCLR       |   | <SDM_CLR [1]> | Request of the current SDM Clearance value (dimensionless).                       |
| SCRS       |   | <SDM_CRS [1]> | Request of the current SDM Course value (dimensionless).                          |
| SD0        |   | <SDM [1]>     | Request of the current SDM value (dimensionless).                                 |
| SD1        |   | <SDM [µA]>    | Request of the current SDM value in µA.   |
| THD_150    |   | <%>           | Request of the THD distortion-value of 150-Hz signal in %.                        |
| THD_90     |   | <%>           | Request of the THD distortion-value of 90-Hz signal in %.                         |
| VIEW       | NORMAL<br>LARGE   | READY         | This function enables the display to be switched between normal- and large views. |

**3.20.3.3 Remote Control Commands of the VOR mode**

| Command   | Parameter | Response | Function   |
|-----------|-----------|----------|--|
| AC8       |           | <CODE>   | Request of the identifier CODE.  |
| AF0       |           | <Hz>     | Request of the AF frequency of 30-Hz signal in Hz.   |
| AF1       |           | <Hz>     | Request of the AF frequency of 9960-Hz signal in Hz.   |
| AF2       |           | <Hz>     | Request of the AF frequency of 30-Hz FM signal in Hz.  |
| AF8       |           | <Hz>     | Request of the AF frequency (ID) in Hz.  |
| AM0       |           | <%>      | Request of the AM modulation factor of 30-Hz signal in %.  |
| AM1       |           | <%>      | Request of the AM modulation factor of 9960-Hz signal in %.  |
| AM8       |           | <%>      | Request of the AM modulation factor (ID) in %.   |
| AM9       |           | <%>      | Request of the AM modulation factor (Voice) in %.  |
| BE        |           | <DEG>    | Request of the BEARING angle in °degree.   |
| DIST_9960 |           | <%>      | Request of the AM distortion-value of 9960-Hz signal in %.   |
| FA0       |           | READY.   | Stops the continuous output that was started with FA2.   |
| FA2       |           | READY.   | <p>Activates the continuous repetition of a set of values. The output rate is defined by the current measurement interval time. All values are transmitted as integer values, multiplied with a constant factor:</p> <p>RF level [dBm], factor: 10<br/>           Bearing [DEG], factor: 100<br/>           AM-Mod30 [%], factor: 100<br/>           AM-Mod9960 [%], factor: 100<br/>           FM-Deviation [Hz], factor 10<br/>           FM-Index [1], factor: 10</p> |
| FM0       |           | <Hz>     | Request of the FM-Hub in Hz.   |



| Command | Parameter | Response                   | Function                               |
|---------|-----------|----------------------------|--|
| FM1     |           | <1>                        | Request of the FM-Index in Hz.         |
| FMEAS   |           | <Hz> e.g.<br>"108050000Hz" | Request of the MEAS-F frequency in Hz. |

**3.20.3.4 Remote Control Commands of the MARKER BEACON mode**

| Command | Parameter | Response                  | Function  |
|---------|-----------|---------------------------|---|
| AF4     |           | <Hz>                      | Request of the AF frequency of the 3000-Hz signal in Hz.  |
| AF5     |           | <Hz>                      | Request of the AF frequency of the 1300-Hz signal in Hz.  |
| AF6     |           | <Hz>                      | Request of the AF frequency of the 400-Hz signal in Hz.   |
| AF7     |           | <Hz>                      | Request of the AF frequency of identifier in Hz.  |
| AM4     |           | <%>                       | Request of the AM-modulation factor of 3000-Hz signal in %.   |
| AM5     |           | <%>                       | Request of the AM-modulation factor of 1300-Hz signal in %.   |
| AM6     |           | <%>                       | Request of the AM-modulation factor of 400-Hz signal in %.  |
| AM7     |           | <%>                       | Request of the AM-modulation factor of identifier in %.   |
| FA0     |           | READY.                    | Stops the continuous output that was started with FA2.  |
| FA2     |           | READY.                    | Activates the continuous repetition of a set of values. The output rate is defined by the current measurement interval time. All values are transmitted as integer values, multiplied with a constant factor:<br><br>RF level [dBm], factor: 10<br>AM-Mod400 [%], factor: 100<br>AM-Mod1300 [%], factor: 100<br>AM-Mod3000 [%], factor: 100<br>AM-Mod ID [%], factor: 100 |
| FMEAS   |           | <Hz> e.g.<br>"75000000Hz" | Request of the MEAS-F frequency in Hz.  |

**3.20.3.5 Remote Control Commands of the Data Logger mode**

| Command   | Parameter                    | Response               | Function  |
|---|------------------------------|------------------------|---|
| CLEARACTIVELIST   |                              | READY                  | Clears content of active list.  |
| CLEARALLLISTS   |                              | READY                  | Clears all lists of current mode / channel.   |
| DL_START  |                              | READY                  | Start Data Logging  |
| DL_STOP   |                              | READY.                 | Stop Data Logging   |
| GETACTIVELIST   |                              | List Nr.               | Shows active list   |
| GETFREEMEMORY   |                              | <MB>                   | Request of the free capacity on internal flash memory in MB.  |
| GETLISTSIZE   |                              | <Nr>                   | Request list size of the active list.   |
| SAVEACTIVELIST2USB  | FileName                     | MOUNT<br>COPY<br>READY | Store on USB stick  |
| SELECTLISTPARAM<br>Example:<br>SELECTLISTPARAM<br>1,2,3,4,5 | ALL<br>NONE<br>Nr., Nr., ... | READY                  | Defines the list selection:<br><br>ALL: everything is logged / exported.<br><br>NONE: nothing is selected.<br><br>Nr.: The parameter with this Nr. is selected. Nr. is meant in default order.<br><br>!Nr.: Parameter is deselected |
| SETACTIVELIST   | List Nr.                     | READY                  | Selects active list for current mode (ILS/MB/VOR)   |

**3.20.3.6 Remote Control Commands of the Setup mode**

| Command   | Parameter                     | Response | Function   |
|---|-------------------------------|----------|--|
| SETUP:<br>INPUT<br>Example:<br>SETUP:INPUT 1.RF | Channel: 1,2<br>Input:RF,BB,? | READY    | Switchover between the RF input signal and the baseband signal to Channel 1 / 2.<br><br>Value:<br>RF (RF input at the front)<br>BB (Base band input at the rear)<br>? (Output with the active input (RF / BB)) |



| Command   | Parameter                              | Response | Function  |
|---|--|----------|---|
| SETUP:<br>BBLEVEL<br><br>Example:<br>SETUP:BBLEVEL 100mV              | Level:<br>- 0.5V<br>- 5V<br>- ?        | READY    | Input sensitivity for the baseband input. Always applies to both channels. (Channel 1 / 2).<br><br>? (Output of the set level)                                |
| SETUP:<br>ANALOG_OUT1   | CH1_DDM<br>CH1_BB_FULL<br>CH1_BB_AUDIO | READY    | Selects the source for Analog Out 1.  |
| SETUP:<br>ANALOG_OUT2   | CH2_DDM<br>CH2_BB_FULL<br>CH2_BB_AUDIO | READY    | Selects the source for Analog Out 2.  |
| SETUP:<br>DDM_RANGE_LLZ<br><br>Example:<br>SETUP:DDM_RANGE_LLZ<br>1,4 | Channel:1,2<br>Range:1,2,3,4           | READY    | Selection of predefined DDM ranges (ILS-LLZ), active for analog out and DDM bargraph indication.  |
| SETUP:<br>DDM_RANGE_GS  | Channel:1,2<br>Range:1,2,3,4           | READY    | Selection of predefined DDM ranges (ILS-GS), active for analog out and DDM bargraph indication.   |
| SETUP:<br>VOLUME  | 0 ... 100                              | READY    | Setting the AF output level in %.   |
| SETUP:<br>SPEAKER   | ON, OFF                                | READY    | Activates the speaker (ON / OFF)  |
| SETUP:<br>ENERGYSAVER   | ON, OFF<br><br>0 ... 60min             | READY    | ON turns the function on.<br>OFF turns the function off.<br>Energy Saver Time input (minutes)<br>Input "0", no energy saver function (display always visible) |
| SETUP:UNIT:DDM  | ?<br><br>1<br><br>μA<br><br>%          | READY    | Request or set DDM unit. Instead of "μA" the string "uA" is accepted.<br><br>"%" may be replaced by "PCT".  |
| SETUP:UNIT:SDM  | ?<br><br>1<br><br>μA<br><br>%          | READY    | Request or set SDM unit. Instead of "μA" the string "uA" is accepted.<br><br>"%" may be replaced by "PCT".  |
| SETUP:UNIT:Level  | ?<br><br>dBm<br><br>dBμV               | READY    | Request or set Level unit.  |





| <b>Command</b>              | <b>Parameter</b>         | <b>Response</b> | <b>Function</b>  |
|-----------------------------|--------------------------|-----------------|--|
| SETUP:UNIT:<br>ILSPHASE     | ?<br>bipolar<br>unipolar | READY           | Request or set ILS phase representation.   |
| SETUP:UNIT:<br>POLARITYDDM  | ?<br>90-150<br>150-90    | READY           | Request or set DDM polarity.   |
| SETUP:UNIT:<br>BARGRAPH     | ?<br>MeasDev<br>Cockpit  | READY           | Request or set Bargraph representation.  |
| SETUP:UNIT:<br>UPPERFREQ    | ?<br>CRS<br>CLR          | READY           | Request or set if the Upper frequency is the Course- or the Clearance- frequency. (while the low frequency is always vice versa) |
| SETUP:UNIT:<br>VORDIRECTION | ?<br>from<br>to          | READY           | Request or set the VOR direction point of view.<br>from: station<br>to: airplane   |



## 4 Service

To guarantee a repair as quick as possible a defective **R&S® EVS 300 ILS / VOR Analyzer** must be sent to the services as stated below.





**To avoid damages on transport the unit should be sent inside its original packing.**

### Shipping address:

Rohde&Schwarz GmbH & Co. KG.  
 Service Center Cologne  
 Graf-Zeppelin-Str. 18  
 D-51147 Köln



**For questions concerning the service or other problems with the unit, please contact us.**

|   |  |
|---|--|
| <br><b>ROHDE&amp;SCHWARZ</b><br>Service Center Cologne |  |
|    | (49) / 2203 / 49-51406<br>(49) / 2203 / 49-51402 |
|    | (49) / 2203 / 49-51642                           |

### 4.1 Guarantee

See our terms and conditions of trade (sales contract).



**During the guarantee a defective internal battery may only be changed by a Rohde & Schwarz-Service Centre, otherwise the right to claim under guarantee get lost!**



# 5 Maintenance

## 5.1 Calibration

 **The R&S® EVS 300 ILS / VOR Analyzer needs to be calibrated yearly!**

## 5.2 Cleaning

To clean the **R&S® EVS 300 ILS / VOR Analyzer** we recommend the following utensils:

- brush
- soft, lint free cloth

 **Before cleaning R&S® EVS 300 ILS / VOR Analyzer it must be switched OFF!**

**Don't use aggressive cleaner for cleaning the surfaces of the R&S® EVS 300 ILS / VOR Analyzer!**





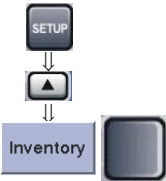
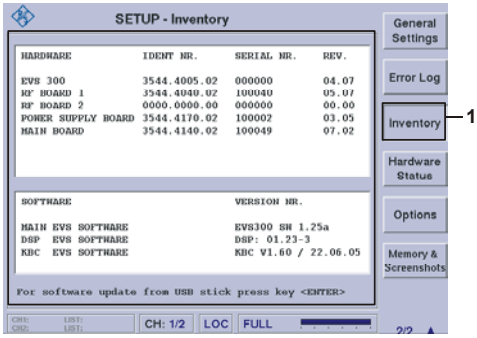

**Electric interfaces must not be cleaned with liquid cleanser e.g. contact spray!**

## 5.3 Software Update

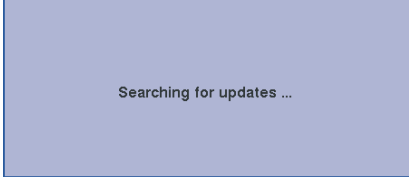
Click on the following website to receive the latest software update for your R&S® EVS 300 ILS / VOR Analyzer:

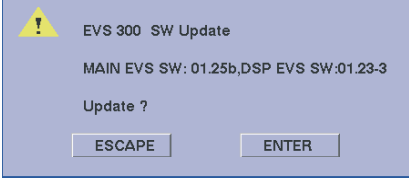
<http://www.rohde-schwarz.com/product/evs300.html>.

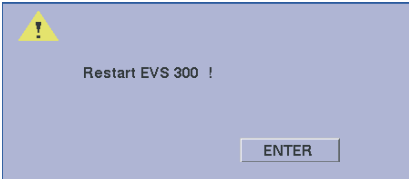
|    |   |   | Function  |
|----|---|---|---|
| 1. |  | Activate setup and switch to the second menu window, press the softkey "Inventory".               | Switching to the "Inventory" menu window.<br> |
| 2. |   | Insert the USB memory stick with the current software update into one of the USB interfaces (29). | wait about 5 seconds  |

|    | Control   | Operation  | Function   |
|----|---|--|--|
| 3. |    | Press the "Enter" (31) button.   | Initialisation of the software update is beginning.<br><br>  |
| 4. |    | Press the "Enter" (31) button.<br><br> <b>Never remove the USB memory stick or switch off the device during the software update!</b><br><br><b>If the USB memory stick is removed during an update, the following error message will be displayed: "Cannot unpack Update". Use the "ESC" button to acknowledge the message. The update mode will be interrupted, i.e., the device can still be operated.</b> | The software update will begin after the security question has been confirmed.<br><br>                                 |
| 5. |  | Press the "Enter" (31) button.   | When the software update is completed, the update programme is ended after confirmation by pressing "Enter".<br><br> |
| 6. |   | Remove the USB memory stick.   |  |
| 7. |  | Press the button twice   | The device needs to be restarted to activate the new software.   |

## 6 Interfaces of the Unit

### 6.1 Front side interfaces

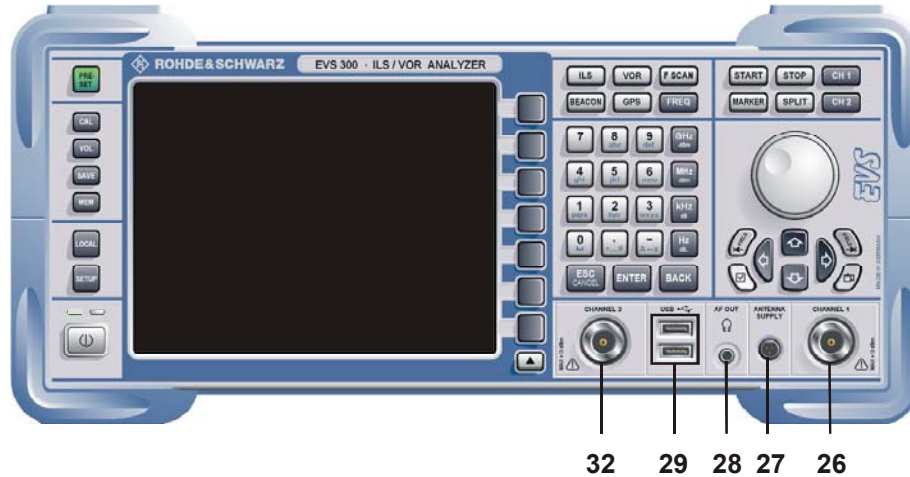

#### 6.1.1 Antenna input 1 (26)

| Item | Interface | Function   |
|------|-----------|--|
| 26   | Channel 1 | RF input for the first channel<br>Connector: N-socket, 50 Ω<br>Input level: max. +13 dBm<br>Frequency range: 70 ... 350 MHz<br>VSWR: <1.5<br><br> <b>The max. input level is +13 dBm, Data stability until 10 dBm guaranteed!</b> |

#### 6.1.2 Active Antenna control (27)

| Item | Interface      | Function   |
|------|----------------|--|
| 27   | ANTENNA SUPPLY | Power supply output for an active receiver antenna.<br>Power supply: 12 VDC / 300 mA |

#### 6.1.3 Headset output (28)

| Item | Interface | Function         |
|------|-----------|------------------|
| 28   | AF OUT    | 3.5 mm jack plug |



6.1.4 USB interface (29)

| Item | Interface | Function  |
|------|-----------|---|
| 29   | USB       | USB 1.1 Standard Twin-Port<br>Transmission rate: max. 12 Mbit/s<br>Power supply: 5 VDC / 500 mA per Port (integrated) |

6.1.5 Antenna input 2 (32)

| Item | Interface | Function  |
|------|-----------|---|
| 32   | Channel 2 | RF input for the second channel (Option EVS-B1)<br>Connector: N-socket, 50 Ω<br>Input level: max. +13 dBm<br>Frequency range: 70 ... 350 MHz<br>VSWR: <1.5<br><b>The max. input level is +13 dBm, data stability until 10 dBm guaranteed!</b> |

6.2 Rear side interfaces

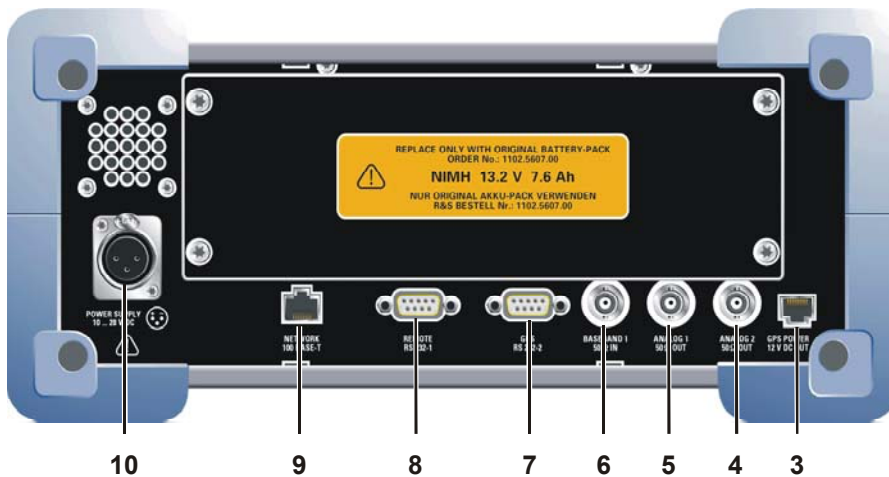

6.2.1 AUX-Power output (3)

| Item | Interface               | Function   |
|------|-------------------------|--|
| 3    | AUX POWER<br>12 VDC OUT | Power supply connector for an external device as e.g. a GSM modem<br>Power supply: 12 VDC / 300 mA<br>Connector: RJ 14 |



**6.2.2 Analogous output 2 (4)**

| Item | Interface            | Function   |
|------|----------------------|--|
| 4    | ANALOG 2<br>50 Ω OUT | <p>Analog output for the baseband signal or, if in ILS mode, as analog DDM output. The selection is made in the setup function</p> <p>BB-Out (Full): Demodulator bandwidth, mode-dependant</p> <p>BB-Out (Audio): 300 ... 3000 Hz, max. 1 V<sub>rms</sub></p> <p>DDM-Range: 1 ... 4</p> <p>Connector: BNC-socket, 50 Ω</p> |

**6.2.3 Analogous output 1 (5)**

| Item | Interface            | Function   |
|------|----------------------|--|
| 5    | ANALOG 1<br>50 Ω OUT | <p>Analog output for the baseband signal or, if in ILS mode, as analog DDM output. The selection is made in the setup function</p> <p>BB-Out (Full): Demodulator bandwidth, mode-dependant</p> <p>BB-Out (Audio): 300 ... 3000 Hz, max. 1 V<sub>rms</sub></p> <p>DDM-Range: 1 ... 4</p> <p>Connector: BNC-socket, 50 Ω</p> |

**6.2.4 Baseband input / Trigger input (6)**

| Item | Interface                 | Function  |
|------|---------------------------|---|
| 6    | BASEBAND IN<br>TRIGGER IN | <p>AF input for the analysis of baseband signals or the trigger input for the trigger mechanism of the internal Data Logger.</p> <p><b>BASEBAND IN:</b><br/>Input level [1]: 0 ... 0.5 / 5 V<sub>p</sub></p> <p><b>TRIGGER IN:</b><br/>Input level: 3.3 ... 12 V<sub>pp</sub><br/>Connector: BNC-socket, 1 MΩ</p> |

<sup>[1]</sup> The setting of the max. AF input level is performed in the setup menu.



**6.2.5 GPS Control interface (7)**

| Item | Interface    | Function  |
|------|--------------|---|
| 7    | GPS RS 232-2 | GPS control interface (serial) for an external GPS receiver<br>COM-parameter: N81<br>Baud-rate: adjustable<br>Connector: SUB-D-plug (9 pin) |

**6.2.6 RS-232 interface (8)**

| Item | Interface       | Function   |
|------|-----------------|--|
| 8    | REMOTE RS 232-1 | Remote control interface (serial) of the <b>R&amp;S® EVS 300 ILS / VOR Analyzer</b><br>COM-parameter: adjustable<br>Baud-rate: adjustable<br>Connector: SUB-D-plug (9 pin) |

**6.2.7 LAN interface (9)**

| Item | Interface             | Function   |
|------|-----------------------|--|
| 9    | NETWORK<br>100 BASE-T | LAN interface (Fast Ethernet Standard)<br>Data transfer rate: 100 Mbit/s<br>Connector: RJ 45 |

**6.2.8 DC Power Supply input (10)**

| Item | Interface  | Function  |
|------|--|---|
| 10   | POWER SUPPLY<br>10 ... 28 VDC<br> | Supply voltage input<br>Input voltage: 10 ... 28 VDC<br>Connector: XLR-plug |



***When an external DC-Power Supply is used the connection sequence of the XLR plug must strictly be met!***

## 7 Technical Data

See data sheet

